



# Service Manual

Models: 1250 - 4000

Series: 100 & 101



**⚠ WARNING**

This manual must only be used by a qualified heating installer / service technician. Read all instructions, including this manual and the XP Plus Installation and Operation Manual, before installing. Perform steps in the order given. Failure to comply could result in severe personal injury, death, or substantial property damage.

Save this manual for future reference.

# Contents

<b>CONTENTS</b> .....	2	Night Setback Screen .....	23
Hazard Definitions .....	2	Pump Screen .....	24-25
<b>PLEASE READ BEFORE PROCEEDING</b> .....	3	Cascade Screens .....	26-28
Handling Ceramic Fiber Materials .....	3	Service Screen.....	29-30
When servicing appliance .....	4	Graph Screens.....	31
Appliance operation .....	4	History Screens.....	32
Appliance water .....	4	<b>2. MAINTENANCE</b>	
Freeze protection fluids .....	4	Maintenance and Annual Startup.....	33-37
WHAT IS IN THIS MANUAL .....	5	<b>3. TROUBLESHOOTING</b>	
<b>1. SERVICE</b>		Before Troubleshooting.....	38
Appliance Piping .....	6	Check Control Module Fuses .....	38
Interface .....	7	Table 3A - Troubleshooting Chart - No Display .....	39
General Operation .....	8	Checking Temperature Sensors .....	40
Control Inputs .....	9	Table 3F - Troubleshooting Chart - Noisy System .....	41
Control Outputs.....	10	Table 3G - Troubleshooting Chart - Fault Messages .	42-50
Table 1A - Sequence of Operation .....	11	Combustion Analysis Procedure .....	51
Initial Setup Screen .....	12	Table 3H - Flue Products .....	51
Viewable and Changeable Control Parameters.....	13	Table 3I - Troubleshooting Chart - Combustion Levels .	52
Set Point Screens .....	13-15	Gas Valve Adjustment Procedure .....	52
Ramp Delay Screen .....	16-17	Revision Notes .....	Back Cover
BMS Screens .....	18-20		
Advanced Setup Screen.....	21-22		

## Hazard definitions

The following defined terms are used throughout this manual to bring attention to the presence of hazards of various risk levels or to important information concerning the life of the product.

### **DANGER**

DANGER indicates an imminently hazardous situation which, if not avoided, will result in death or serious injury.

### **WARNING**

WARNING indicates a potentially hazardous situation which, if not avoided, could result in death or serious injury.

### **CAUTION**

CAUTION indicates a potentially hazardous situation which, if not avoided, may result in minor or moderate injury.

### **CAUTION**

CAUTION used without the safety alert symbol indicates a potentially hazardous situation which, if not avoided, may result in property damage.

### **NOTICE**

NOTICE indicates special instructions on installation, operation, or maintenance that are important but not related to personal injury or property damage.

## Please read before proceeding

**⚠ WARNING**

**Installer** – Read all instructions, including this manual and the XP Plus Installation and Operation Manual, before installing. Perform steps in the order given.

**User** – This manual is for use only by a qualified heating installer/service technician. Refer to the XP Plus User's Information Manual for your reference.

Have this appliance serviced/inspected by a qualified service technician at least annually.

Failure to comply with the above could result in severe personal injury, death, or substantial property damage.

**NOTICE**

When calling or writing about the appliance – Please have the appliance model and serial number from the appliance rating plate.

Consider piping and installation when determining appliance location (see the XP Plus Installation and Operation Manual).

Any claims for damage or shortage in shipment must be filed immediately against the transportation company by the consignee.

## Handling ceramic fiber materials

### REMOVAL OF COMBUSTION CHAMBER LINING

**⚠ WARNING**

The combustion chamber insulation in this appliance contains ceramic fiber material. Ceramic fibers can be converted to cristobalite in very high temperature applications. The International Agency for Research on Cancer (IARC) has concluded, "Crystalline silica in the form of quartz or cristobalite from occupational sources is carcinogenic to humans (Group 1)." Normal operating temperatures in this appliance are below the level to convert ceramic fibers to cristobalite. Abnormal operating conditions would have to be created to convert the ceramic fibers in this appliance to cristobalite.

The ceramic fiber material used in this appliance is an irritant; when handling or replacing the ceramic materials it is advisable that the installer follow these safety guidelines.

- Avoid breathing dust and contact with skin and eyes.
  - Use NIOSH certified dust respirator (N95). This type of respirator is based on the OSHA requirements for cristobalite at the time this document was written. Other types of respirators may be needed depending on the job site conditions. Current NIOSH recommendations can be found on the NIOSH website at <http://www.cdc.gov/niosh/homepage.html>. NIOSH approved respirators, manufacturers, and phone numbers are also listed on this website.
  - Wear long-sleeved, loose fitting clothing, gloves, and eye protection.
- Apply enough water to the combustion chamber lining to prevent airborne dust.
- Remove the combustion chamber lining from the appliance and place it in a plastic bag for disposal.
- Wash potentially contaminated clothes separately from other clothing. Rinse clothes washer thoroughly.

#### NIOSH stated First Aid.

- Eye: Irrigate immediately.
- Breathing: Fresh air.

## Please read before proceeding

### When servicing appliance –

- To avoid electric shock, disconnect electrical supply before performing maintenance.
- To avoid severe burns, allow appliance to cool before performing maintenance.

### Appliance operation –

- Do not block flow of combustion or ventilation air to the appliance.
- Should overheating occur or gas supply fail to shut off, do not turn off or disconnect electrical supply to circulator. Instead, shut off the gas supply at a location external to the appliance.
- Do not use this appliance if any part has been under water. The possible damage to a flooded appliance can be extensive and present numerous safety hazards. Any appliance that has been under water must be replaced.

### Appliance water –

- Thoroughly flush the system (without appliance connected) to remove sediment. The high-efficiency heat exchanger can be damaged by build-up or corrosion due to sediment.
- Do not use petroleum-based cleaning or sealing compounds in the appliance system. Gaskets and seals in the system may be damaged. This can result in substantial property damage.
- Do not use “homemade cures” or “appliance patent medicines.” Serious damage to the appliance, personnel, and/or property may result.

## What is in this manual?

### Service

#### Near appliance piping

- Typical system components

#### The XP Plus appliance display

- Display panel readout, buttons and their functions

#### Control module inputs

- Control module inputs and options

#### Control module outputs

- Control module outputs and options

#### General

- How the appliance operates
- How the control module operates
- Access modes -- user and installer
- Sequence of operation

#### Control panel menu access

- Accessing programming mode and locating menus  
(See separate guide covering the PC interface.)

#### Control panel parameter access

- Accessing and changing parameters from the display panel

#### Quick start information -- parameter table

- An index of available adjustments and readouts, where to access them and where to find detailed information.

#### XP Plus appliance operation

- Initial Setup
- Set Points
- Outdoor Reset
- Ramp Delay
- BMS
- Advanced Setup
- SH Night Setback
- HW Night Setback
- Cascade
- Pumps
- Service Notification

### Maintenance

- Service and maintenance schedules
- Address reported problems
- Inspect appliance area and appliance interior
- Clean condensate trap
- Check all piping for leaks
- Check air openings
- Flue vent system and air piping
- Check water system
- Check expansion tank
- Check appliance relief valve
- Inspect ignition electrode
- Check ignition ground wiring
- Check all appliance wiring
- Check control settings
- Perform start-up and checks
- Check burner flame
- Check flame signal
- Check flue gas temperature
- General maintenance
- Review with owner
- Cleaning appliance heat exchanger
- Oiled bearing circulators

### Troubleshooting

- Troubleshooting table - No display
- Checking temperature sensors
- Sensor tables
- Troubleshooting table - Fault messages displayed on appliance interface
- Combustion analysis procedure
- Gas valve adjustment procedure

# 1 Service

## Appliance piping

This piping reference is included to specify the *Appliance Piping* specific to the XP Plus appliance. This piping scheme is important for proper operation of the control. See the XP Plus Installation and Operation Manual for more detailed piping diagrams.

### Single Water - Primary / Secondary Piping

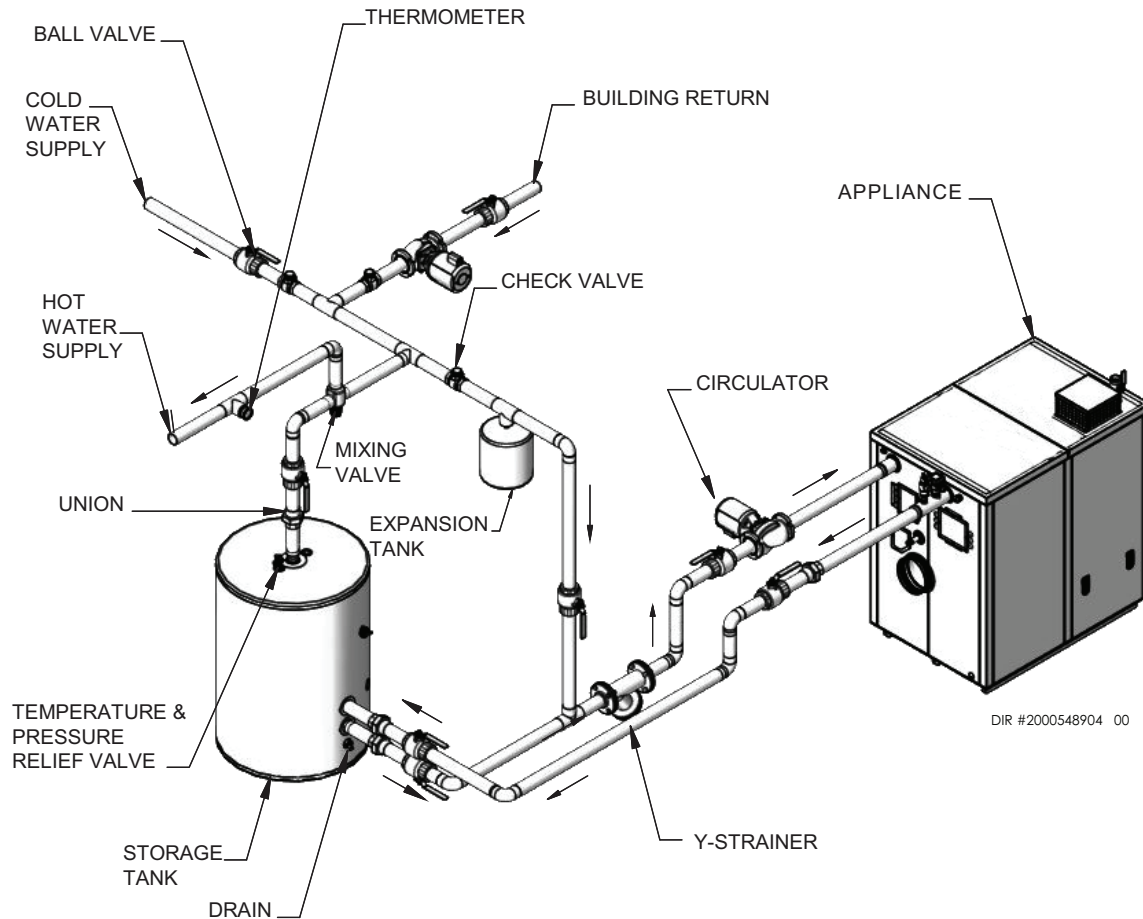

# 1 Service *(continued)*

## Display Interface

The Home Screen displays basic information on how the unit is running. It is divided into the following sections: Status, Demand, Modulation, Sensors, and Navigation.

**Figure 1-1 Home Screen**



- The **Status** Section is located on the top left of the screen and displays how the unit is currently running (i.e. Off, Stand-by, Blocking, and Lockout) including: current driving demand, the next Hot Water Setback scheduled, the reason for any blocking or lockout, and a power button.
- The **Demand** Section is located on the bottom left of the screen and displays information about the targets and limits of the current demand being serviced.
- The **Modulation** Section is located on the top right of the screen and displays the target modulation of the unit. This section also includes target and actual fan speeds.
- The **Sensor** Section is located on the bottom right of the screen and displays both factory installed and field installed sensor including: Inlet Water Temperature, Delta T Water Temperature, Outlet Water Temperature, Flue Temperature, and HW Tank Temperature.
- The **Navigation** Section is located down the left side of the screen. There are five (5) sections located below the A.O. Smith icon: Home, View, Setup, Information (About), and Settings. The Home Section is the screen shown above. The View Section provides more detailed information including subsections for: History, Cascade, Graphing, and a complete list of current Sensor Values. The Setup Section has several screens to aid in setting up the appliance. The Setup Section includes screens for adjusting: Set Points, Pump Settings, Cascade, BMS, Ramp Delay, and Night Setback. The Information Section provides information about the hardware and software including the current software version of the interface and the version of the boiler control. The Setting Section enables several interface setup features including: Time Setup, Temperature Unit Select, System Update, and WiFi Setup.

# 1 Service

## General Operation

### How the appliance operates

The XP Plus uses an advanced stainless steel heat exchanger to transfer heat from the flue products to the water. An electronic control module monitors various inputs to initiate a call for heat. The blower provides air to the burner and forces the flue products out of the combustion chamber and into the vent system. The control module regulates the blower speed to control the firing rate of the unit. The modulating gas valve monitors the amount of combustion air being pulled into the blower and regulates the amount of gas supplied, which then mixes with the combustion air and is supplied to the burner.

### How the control modules operate

The XP Plus appliance is equipped with a control module. The control module receives inputs from appliance sensors and external devices. The control module activates and controls the blowers and gas valves to regulate heat input and switches the system and DHW pump on and off as needed. The user programs the control module to meet system needs by adjusting control parameters. These parameters set operating temperatures and appliance operating modes.

### Sequence of operation

Table 1A (page 11) shows control module normal sequences of operation.

### Access modes

#### User

The USER can set the tank set point and turn the unit OFF and ON.

#### Installer

Most parameters are available only to the INSTALLER, accessible only by entering the installer password (5309) when selecting the Setup Section.

**NOTE:** The password will timeout after an hour from entry.



# 1 Service *(continued)*

## Control inputs

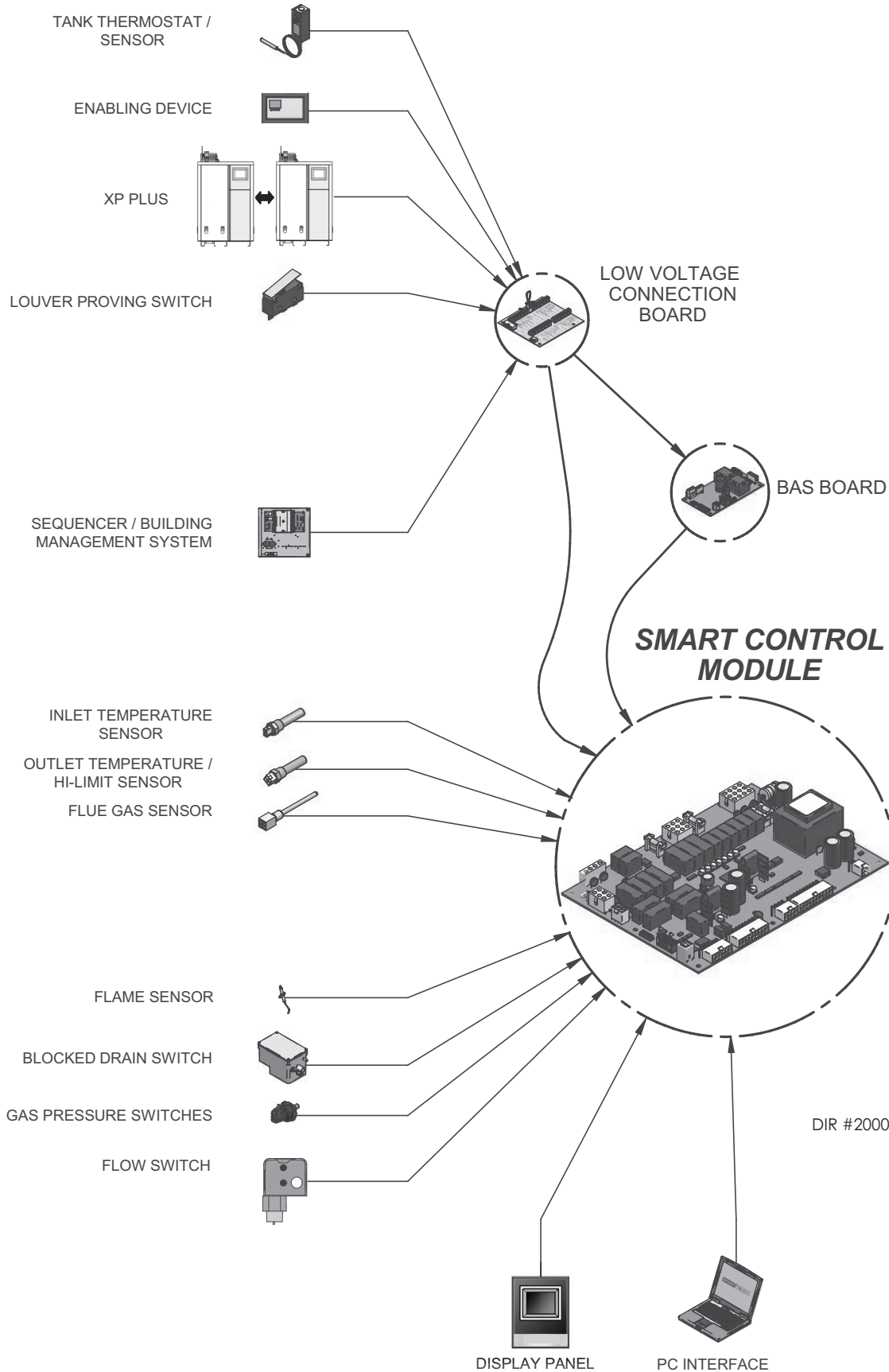

DIR #2000549760 00

# 1 Service

## Control outputs

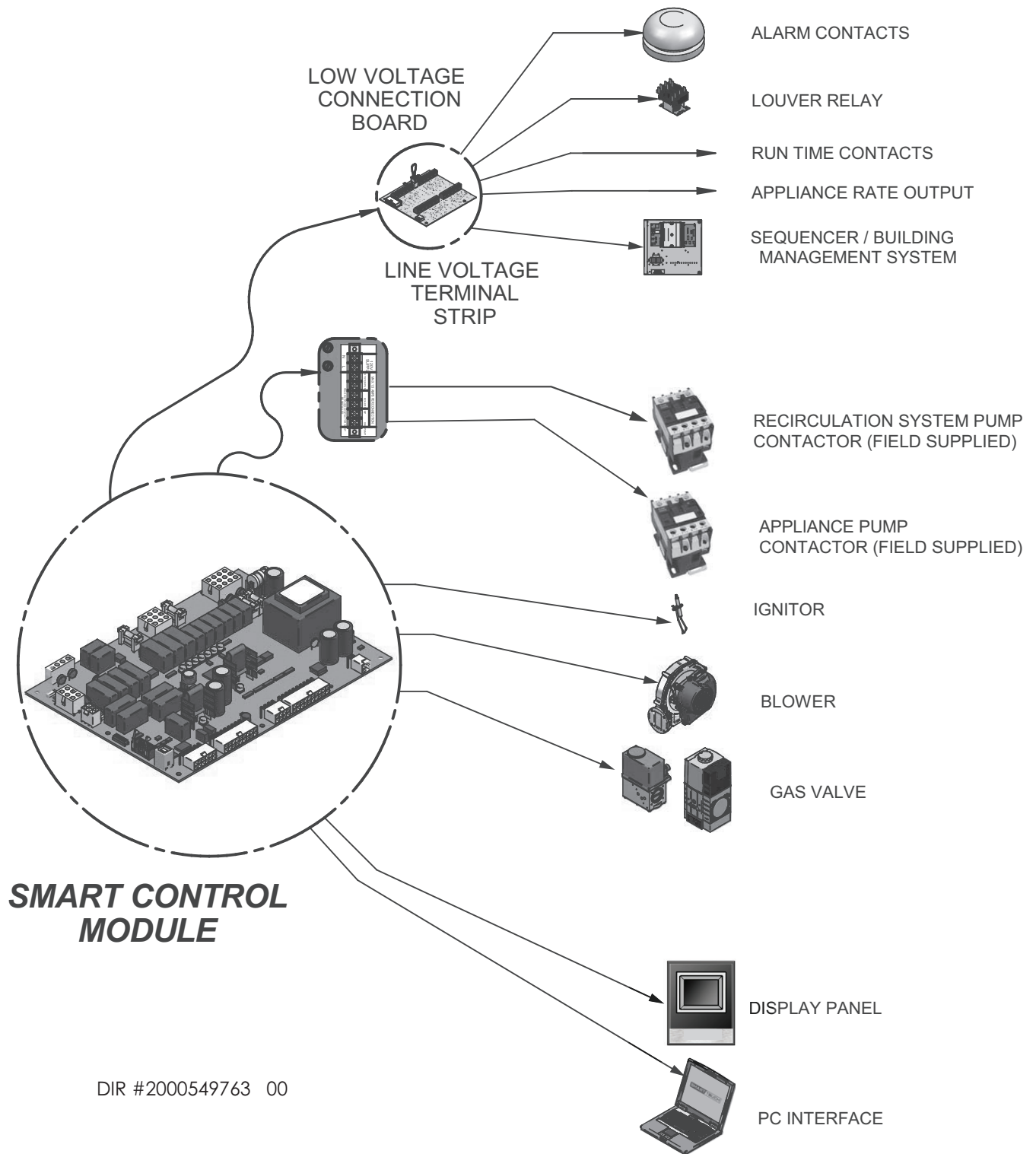

DIR #2000549763 00

# 1 Service *(continued)*

**Table 1A** Sequence of Operation

## Sequence of operation

<b>1.</b>	Upon a call for heat, the control turns on the appliance pump.
<b>2.</b>	Energizes the optional louver relay.
<b>3.</b>	The control confirms that the gas pressure switch, blocked drain switch, limits, louver proving switch (optional) and contacts close. The Pre-Purge cycle begins.
<b>4.</b>	The control confirms that the blower comes up to the desired speed.
<b>5.</b>	Once the Pre-Purge cycle is complete, the control lowers the blower speed, initiates sparking of the ignition electrode, and opens the gas valve.
<b>6.</b>	After a short wait, the control stops sparking and checks for the presence of flame current through the flame sense electrode.
<b>7.</b>	If the control does not detect flame current, the control will retry one (1) time before locking out, until the RESET button on the touch screen LCD is pressed.
<b>8.</b>	If the control detects flame current, the control will hold the blower speed constant for a few seconds to allow the flame to stabilize, then begin modulating the firing rate in order to maintain the controlling sensor to the desired set point temperature.
<b>9.</b>	Once the call for heat is satisfied, the control will turn off the gas valve and begin the Post-Purge cycle. The pump will begin Pump Delay cycles.
<b>10.</b>	At the end of the Post-Purge cycle, the louver relay contacts will de-energize.
<b>11.</b>	The control verifies that the blowers stop running.
<b>12.</b>	At the end of the Pump Delay cycle, the pump will be turned off.

# 1 Service

## Initial Setup Screen

Figure 1-2 Settings

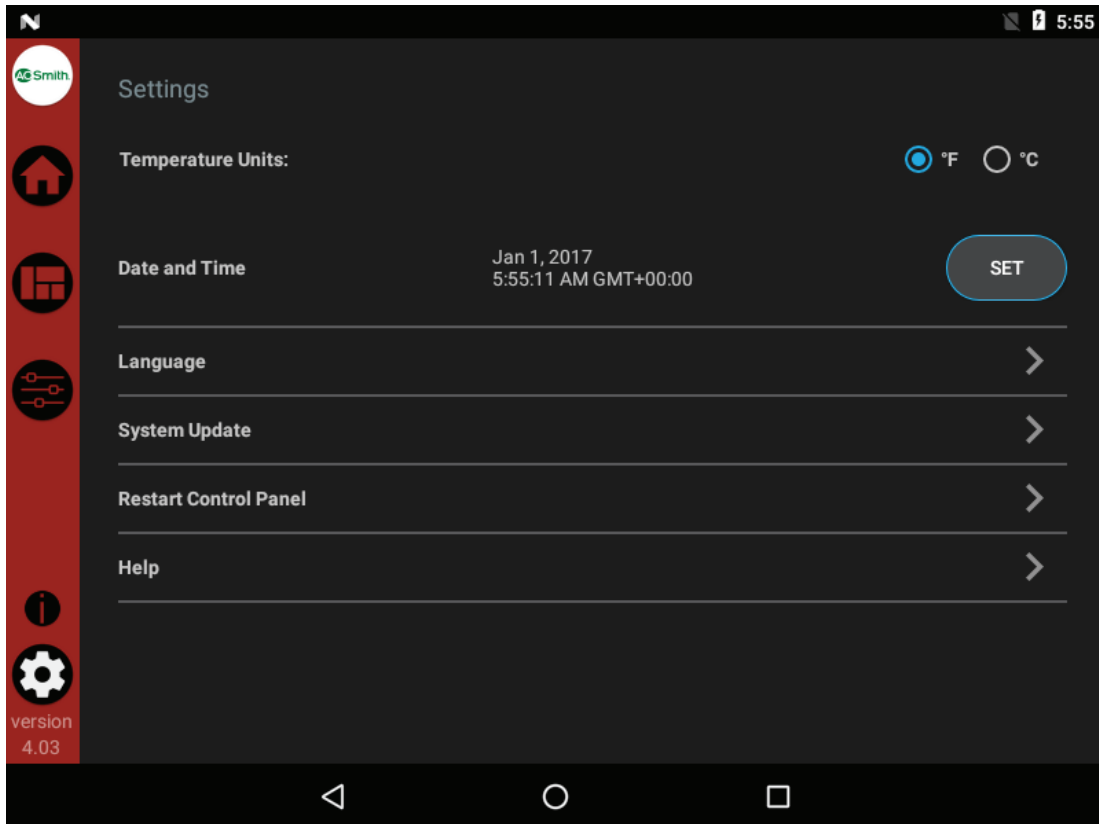

### Rapid Setup

#### Clock and Date

The control uses an internal clock for the night setback feature and for logging of events. For these features to work correctly, the clock must be set when the appliance is first installed or anytime the appliance has been powered off for more than four (4) hours. This parameter must be accessed to set the clock. If the unit is connected to the internet, the time will adjust based on the time zone selected.

#### Temperature units (°C / °F)

The control can be configured to display temperature in either °C or °F.

#### Set clock

The control has a built-in clock that it uses for its night setback feature and for logging events. This clock must be set when the appliance is installed and anytime the appliance has been powered off for more than one day. Use the following procedure to set the clock:

1. Press the SETTINGS button along the left side of the screen (see FIG. 1-1).
2. Press the SET button across from the date and time (see FIG. 1-2).
3. Proceed to set the date, time, and time zone. **NOTE:** Automatic Time Zone will not work.
4. Temperature units may also be set here. This item may be used to automatically sync the time.
5. Press the Home, View, or Back button to exit.

# 1 Service *(continued)*

## Viewable and changeable control parameters

**CAUTION**

Before changing parameters, note the settings so that the unit can be returned to its original operating parameters.

### Set Point Screens

Figure 1-3 Set points HW\_Screen

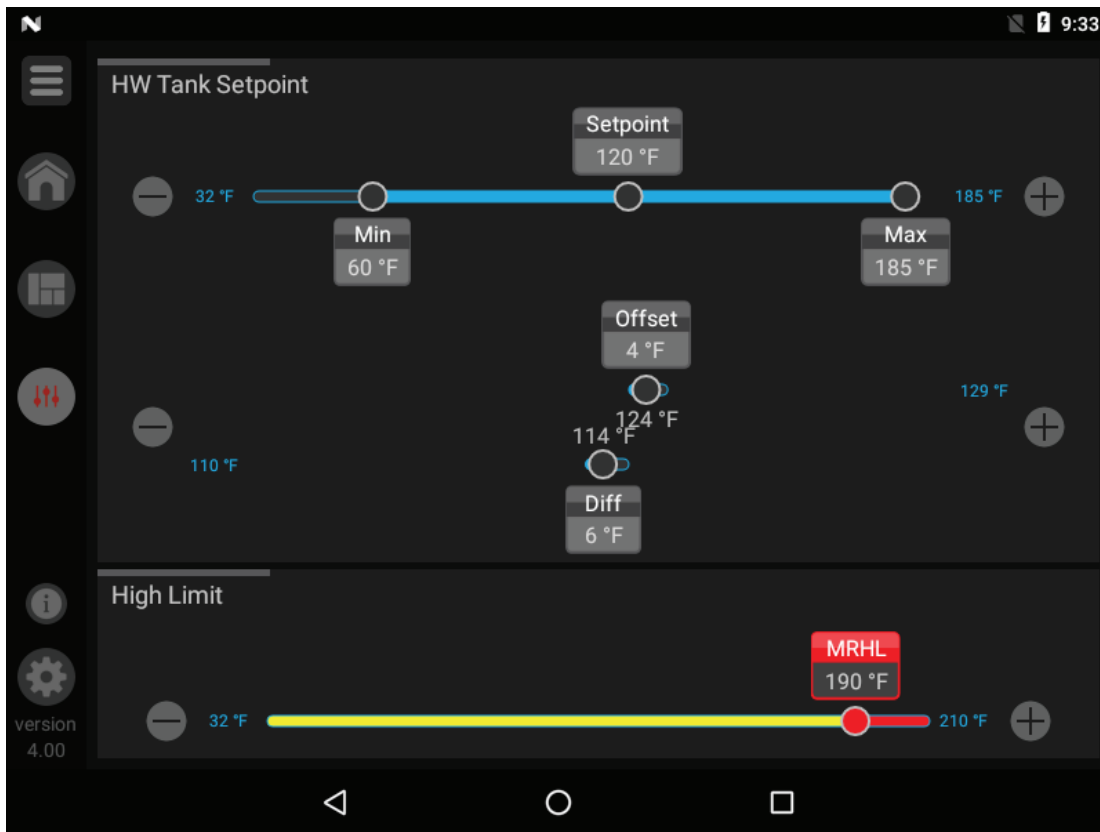

# 1 Service

**Table 1B** Set Points (This table lists control module parameters; use the sub-tab under the Setup tab to access them.)

Menu	Parameter Name (as shown on the LCD screen)	Min	Max	Default
		Value	Value	Value
<b>SET POINTS</b>	System Pump Anti-Seize Time	0	40	0.33
	High Limit: MRHL	32	210	210
	HW Tank Set point: Set point	MIN	MAX	120
	HW Tank Set point: Min	32	MAX	N/A
	HW Tank Set point: Max	MIN	185	N/A
	HW Tank Set point: Diff	0	10	6

# 1 Service *(continued)*

## Set Points

### High Limit: ARHL

The control contains an integral Auto Reset High Limit (ARHL) on the outlet of the heat exchanger. Once the outlet temperature exceeds the ARHL set point, the appliance will shut down and lock out. Once the outlet temperature has dropped below this set point, the RESET button on the LCD display can be pressed to reset this lockout. If RESET is not pressed, the control will automatically reset the lockout after five (5) minutes.

### High Limit: MRHL

The control contains an integral Manual Reset High Limit (MRHL) on the outlet of the heat exchanger. Once the outlet temperature exceeds the MRHL set point, the appliance will shut down and lock out. Once the outlet temperature has dropped below this set point, the RESET button on the LCD display must be pressed to clear this lockout.

### HW Tank Set Point: Set Point

By installing a tank sensor, the control can perform the tank thermostat function. The control automatically detects the presence of this sensor, and generates a call for heat when the tank temperature drops below the tank set point minus the differential, and finishes the call for heat when the tank temperature reaches tank set point.

### HW Tank Set Point: Min

This setting controls the minimum user set point for the tank temperature.

### HW Tank Set Point: Max

This setting controls the maximum user set point for the tank temperature.

### HW Tank Set Point: Differential

When a tank sensor is installed, the tank temperature must drop this amount below the tank set point before the appliance will turn on.

# 1 Service

## Ramp Delay Screen

Figure 1-4 Ramp Delay

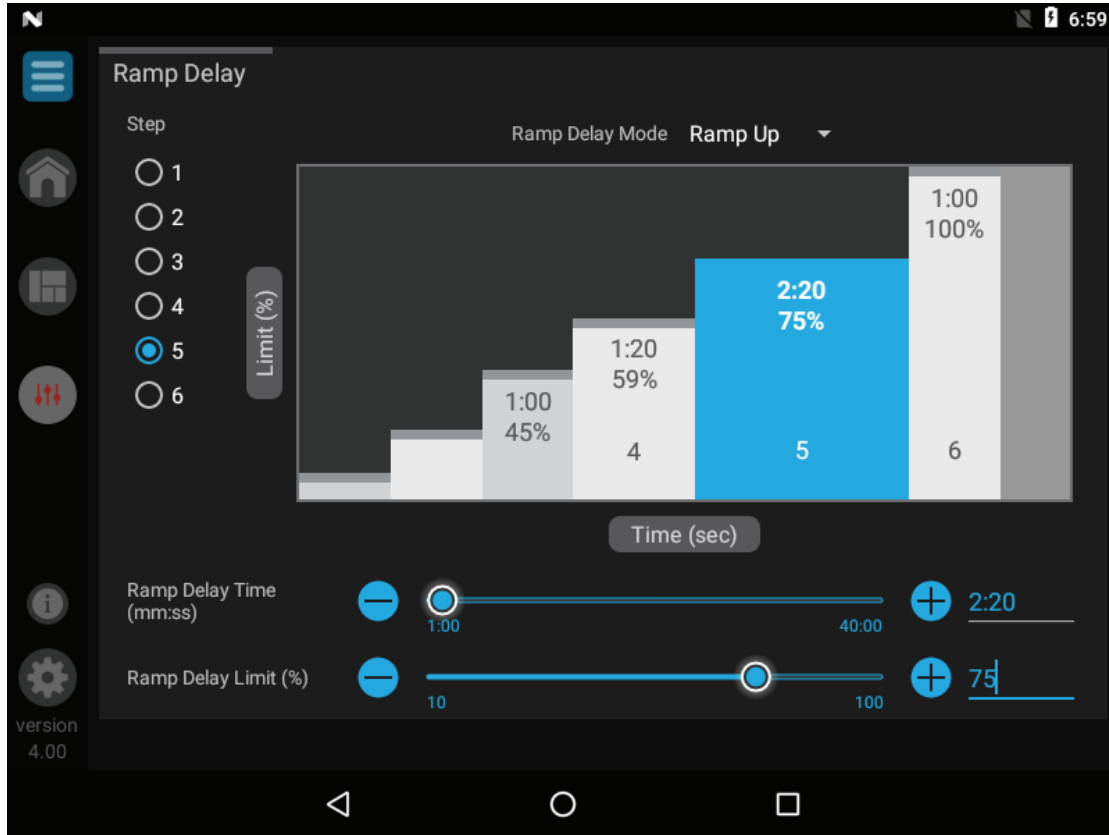

Table 1C Ramp Delay (This table lists control module parameters; use the sub-tab under the Setup tab to access them.)

Menu	Parameter Name (as shown on the LCD screen)	Min	Max	Default
		Value	Value	Value
RAMP DELAY	Ramp Delay Mode	N/A	N/A	N/A
	Step 1: Ramp Delay Time	1	40	2
	Step 1: Ramp Delay Limit (%)	10	100	20
	Step 2: Ramp Delay Time	1	40	2
	Step 2: Ramp Delay Limit (%)	10	100	30
	Step 3: Ramp Delay Time	1	40	2
	Step 3: Ramp Delay Limit (%)	10	100	40
	Step 4: Ramp Delay Time	1	40	1
	Step 4: Ramp Delay Limit (%)	10	100	55
	Step 5: Ramp Delay Time	1	40	1
	Step 5: Ramp Delay Limit (%)	10	100	75
	Step 6: Ramp Delay Time	1	40	1
	Step 6: Ramp Delay Limit (%)	10	100	100



# 1 Service *(continued)*

## Ramp Delay

### Ramp Delay (Enable / Disable)

This parameter allows the installer to enable or disable the ramp delay.

### Ramp Delay

The Interface can be programmed to limit the firing rate for a fixed period of time at the start of a heating demand. There are six (6) possible limits, each with their own time delay. The first limit applies as soon as the burner starts. Once its time delay expires, the second limit is applied and its timer begins. The control steps through these limits until the 6th (sixth) limit expires. Note, however, that the 6th limit will also limit the rate for the rest of that heat demand.

# 1 Service

## BMS Screens

Figure 1-5 BMS\_Screen A

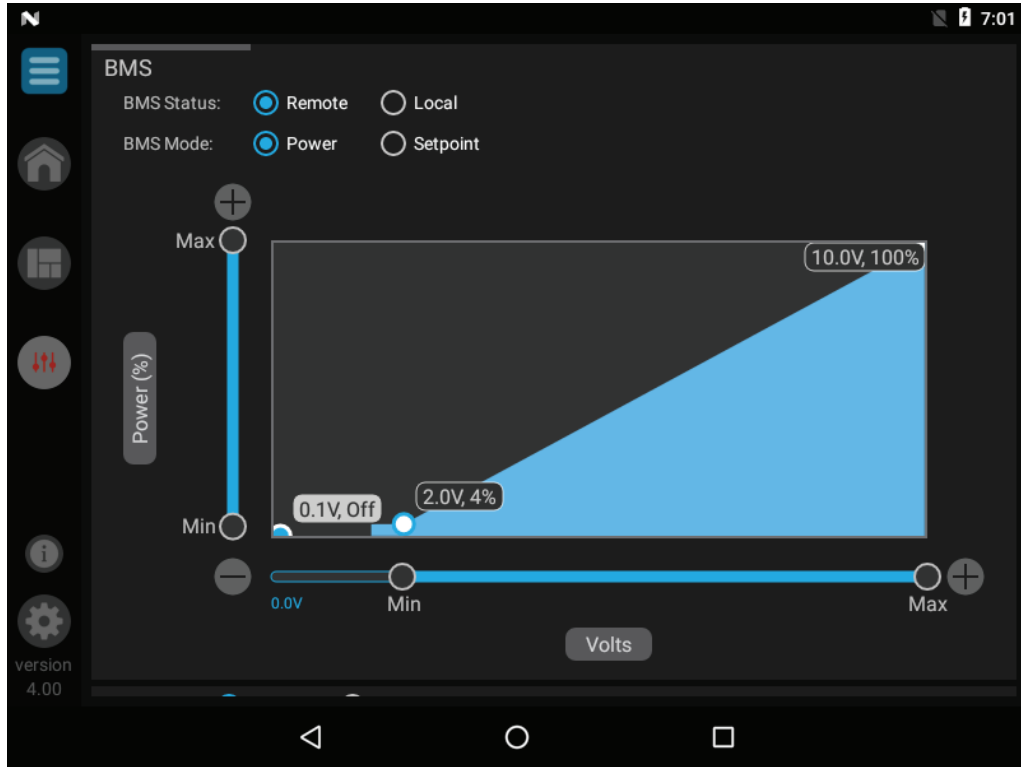
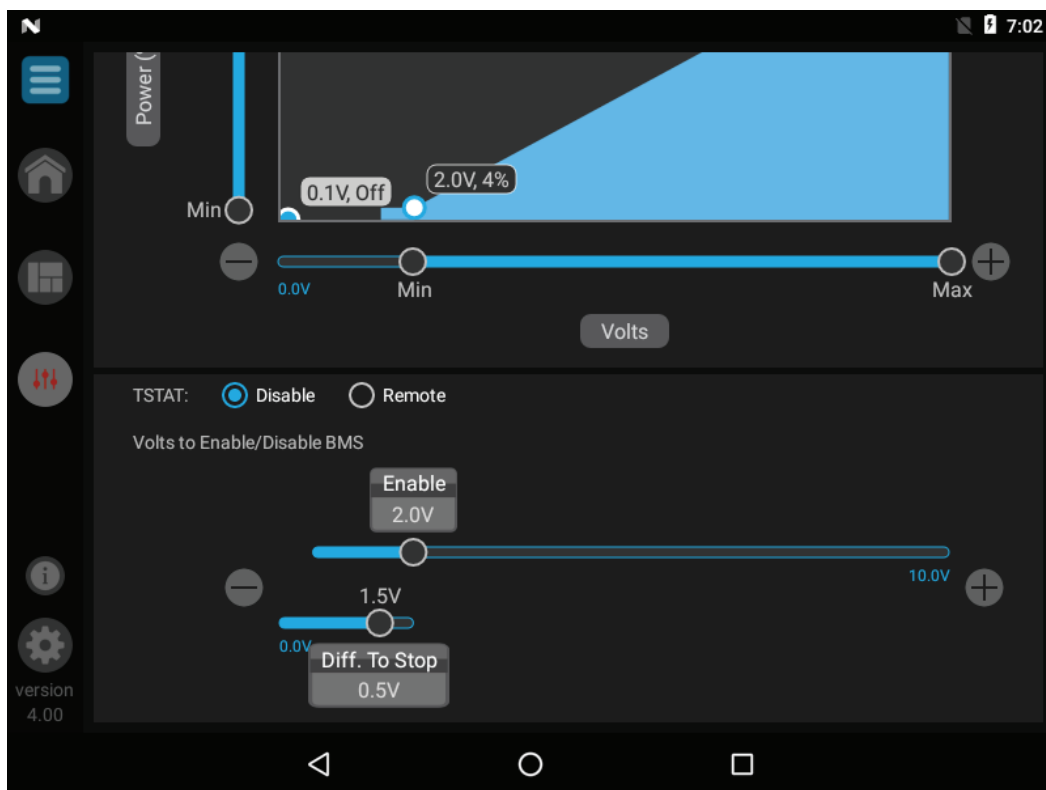

Figure 1-6 BMS\_Screen B



# 1 Service *(continued)*

**Table 1D BMS / BAS** (This table lists control module parameters; use the sub-tab under the Setup tab to access them.)

Menu	Parameter Name (as shown on the LCD screen)	Min	Max	Default
		Value	Value	Value
BMS	BMS Status	ACTIVE	INACTIVE	INACTIVE
	BMS Mode	POWER	SETPOINT	POWER
	Power (%): Min	4	POWER MAX	4 OR 5
	Power (%): Max	POWER MIN	100	100
	Volts: Min	0	VOLTS MAX	2
	Volts: Max	VOLTS MIN	10	10
	Set point (F): Min	32	SET POINT MAX	69.8
	Set point (F): Max	SET POINT MIN	185	179.6
	Volts to Enable / Disable BMS: Enable	0	10	2
	Volts to Enable / Disable BMS: Diff. to Stop	0	10	0.5
	BMS TSAT	ENABLE	DISABLE	DISABLE
BAS	BAS Active / Inactive	ENABLE	DISABLE	DISABLE
	BAS Out of Order Timer	5	120	30

## BMS

### BMS (Active / Inactive)

The set point or modulation of the appliance may be controlled through the 0 - 10V Building Management System (BMS) input. When the parameter is set to INACTIVE, the 0 - 10V input will be ignored. When set to ACTIVE, the set point or modulation will be controlled by the voltage on the 0 - 10V input, as described below.

### BMS Mode (Power / Set Point)

When BMS is set to ACTIVE, this parameter will determine if the voltage on the 0 - 10V BMS input is converted to modulation or a set point. When set to POWER, the voltage determines the modulation of the appliance. When set to SETPOINT, voltage determines the set point used by the appliance.

### BMS Volts at Minimum (Power or Set Point)

When BMS is set to ACTIVE, this parameter will determine the voltage on the 0 - 10V BMS input that represents the minimum modulation or set point. Any voltage less than this value will not change the modulation or set point used by the appliance.

### BMS Volts at Maximum (Power or Set Point)

When BMS is set to ACTIVE, this parameter will determine the voltage on the 0 - 10V BMS input that represents the maximum modulation or set point. Any voltage above this value will not change the modulation or set point used by the appliance.

### BMS Rate at Minimum Volts

This parameter is visible only when BMS Mode is set to POWER. The value of this parameter determines the modulation rate when the voltage on the 0 - 10V BMS input is equal to or less than the BMS Volts at Minimum parameter value.

### BMS Rate at Maximum Volts

This parameter is visible only when BMS Mode is set to POWER. The value of this parameter determines the modulation rate when the voltage on the 0 - 10V BMS input is equal to or more than the BMS Volts at Maximum parameter value.

# 1 Service

## BMS Set Point at Minimum Volts

This parameter is visible only when the BMS Mode is set to SETPOINT. The value of this parameter determines the set point when the voltage on the 0 - 10V BMS input is equal to or less than the BMS Volts at Minimum parameter value.

## BMS Set Point at Maximum Volts

This parameter is visible only when BMS Mode is set to SETPOINT. The value of this parameter determines the set point when the voltage on the 0 - 10V BMS input is equal to or more than the BMS Volts at Maximum parameter value.

## BMS Volts to Enable

When BMS is set to ACTIVE, the appliance may be enabled either through the ENABLE input, or by the voltage on the 0 - 10V BMS input (see BMS Tstat Enable Mode below). If enabled through the voltage on the 0 - 10V BMS input, the value of this parameter determines the voltage at which the appliance becomes enabled.

## Differential to Stop BMS Demand

When BMS is set to ACTIVE, and the appliance is enabled through the voltage on the 0 - 10V BMS input, the voltage must go below the BMS Volts to Enable value by this amount in order to end the demand.

## BMS Tstat Enable Mode

In order to use the ENABLE input to enable the appliance, this parameter must be set to ACTIVE. To use the voltage on the 0 - 10V BMS input to enable the appliance, this parameter must be set to INACTIVE.

## BAS

### BAS Active / Inactive

The appliance is capable of being monitored and/or controlled by a Building Automation System (BAS) through either a ModBus RTU or BACnet MS/TP communication system. In addition, it can communicate through a BACnet TCP/IP system with the use of an optional gateway. See the XP Plus ModBus Manual for details on the points that are available. If the appliance is to be monitored by the BAS system, the BAS Active / Inactive parameter should be set to INACTIVE. If the appliance is to be controlled through a BAS system, the BAS Active / Inactive parameter must be set to ACTIVE.

### BAS Out of Order Timer

When the appliance is being controlled by the BAS system, the commands it sends to the appliance must be refreshed periodically. If the appliance does not receive a command for too long, the appliance will revert to its local readings (e.g., enable input, temperatures, etc. ) until a new command is received from the BAS system. For most commands, this timeout is fixed at 10 minutes. Certain commands (0 - 10V BMS voltage and tank temperature) can change quickly, so they need to be refreshed more often. The timeout for these commands is controlled by the BAS Out of Order Timer.

# 1 Service *(continued)*

## Advanced Setup Screen

Figure 1-7 Advanced Setup

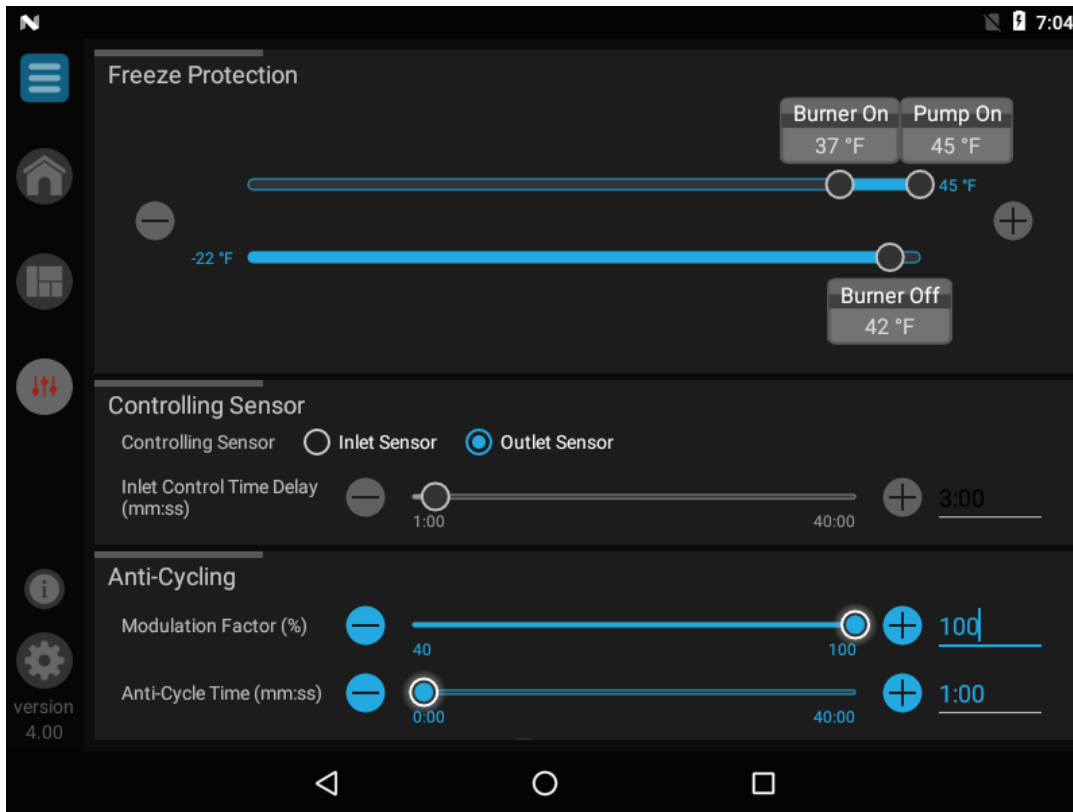

Table 1E Advanced Setup (This table lists control module parameters; use the sub-tab under the Setup tab to access them.)

Menu	Parameter Name (as shown on the LCD screen)	Min	Max	Default
		Value	Value	Value
ADVANCED SETUP	Freeze Protection; Pump On	-22	45	44.6
	Freeze Protection; Burner On	-22	45	37.4
	Freeze Protection; Burner Off	-22	45	5
	Anti-Cycling Time	0	40	10
	Anti-Cycling Diff	0	54	1

### Advanced Setup

#### Freeze Protection Pump On

The control will turn on the appliance and appliance pump output whenever the inlet temperature drops below this setting. This is done to prevent the water in the heat exchanger from freezing. The temperature at which the pump outputs are turned on can be accessed through the Freeze Protection Pump On parameter.

#### Freeze Protection Burner On

If running the pumps does not prevent the inlet temperature from falling closer to freezing, the control will fire the burner at low fire if in the ON state. The installer can adjust the temperature at which the burner fires by adjusting the Freeze Protection Burner On parameter.

# 1 Service

## Freeze Protection Burner Off

Once the burner has started firing due to a low inlet temperature, the inlet temperature must increase by this amount before the burner turns back off. The installer can adjust this differential by accessing the Freeze Protection Burner Off parameter.

## Anti-Cycling Time

Once a HW demand has been satisfied, a set amount of time must elapse before the control will respond to a new HW demand. The control will block the new heat demand and anti-cycling will be shown in the display until the time has elapsed or the water temperature drops below the anti-cycling differential. This parameter can be changed by the installer by accessing the Anti-Cycling Time parameter.

## Anti-Cycling Differential

The control will bypass the anti-cycling time if the inlet water temperature drops too much. The control will use the inlet water temperature at the time the appliance shut off as the starting point. If the inlet temperature drops below this temperature parameter the control will abort anti-cycling and allow the appliance to fire. This parameter can be changed by the installer by the Anti-Cycling Differential parameter.

# 1 Service *(continued)*

## Night Setback Screen

Figure 1-8 HW Night Setback

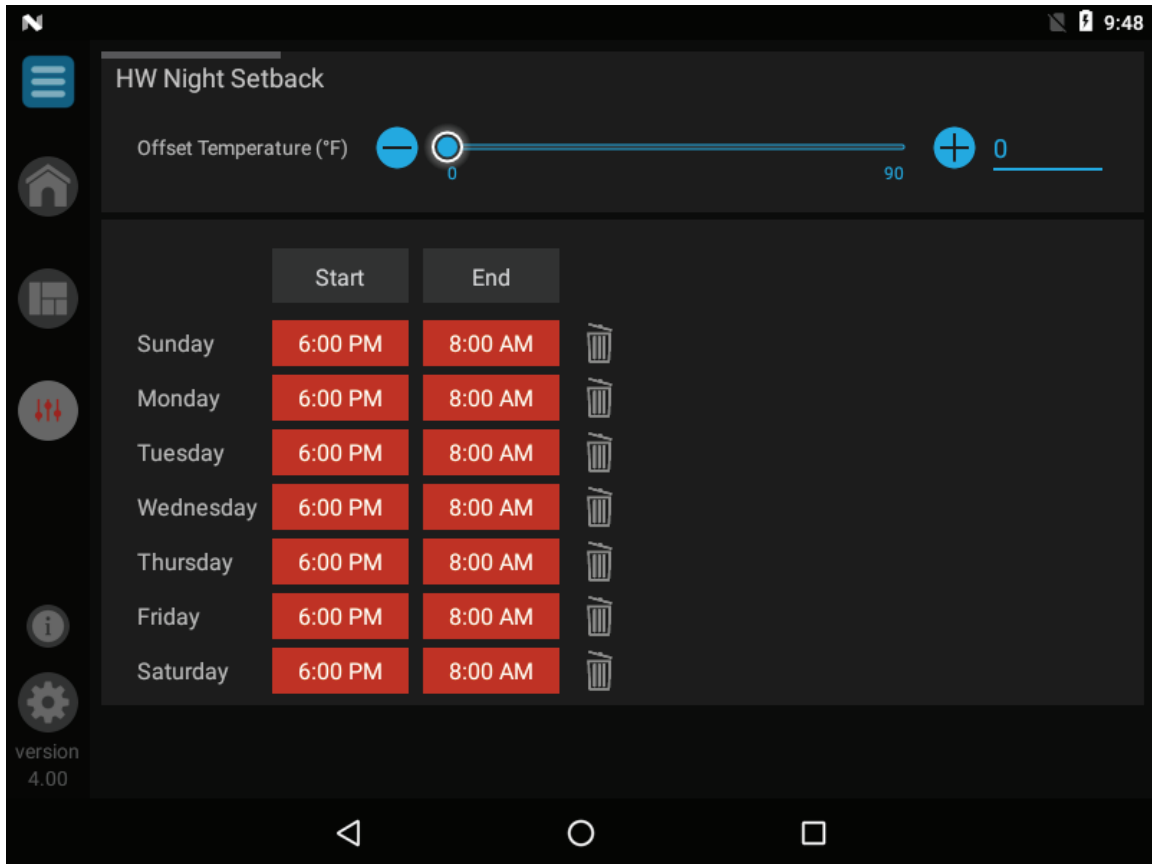

Table 1F HW Night Setback

Menu	Parameter Name (as shown on the LCD screen)	Min	Max	Default
		Value	Value	Value
HW NIGHT SETBACK	Offset Temperature (F)	0	90	0

### HW Night Setback

#### Offset Temperature

Once the internal clock has been set correctly, the SH night setback feature can be used to program a lower set point. The value of this parameter will be subtracted from the normal set point to determine the set point used during night setback. The temperature range for this parameter is 0°F to 90°F (50°C). The feature is turned off with a setting of 0°F.

# 1 Service Pump Screen

Figure 1-9 Pump

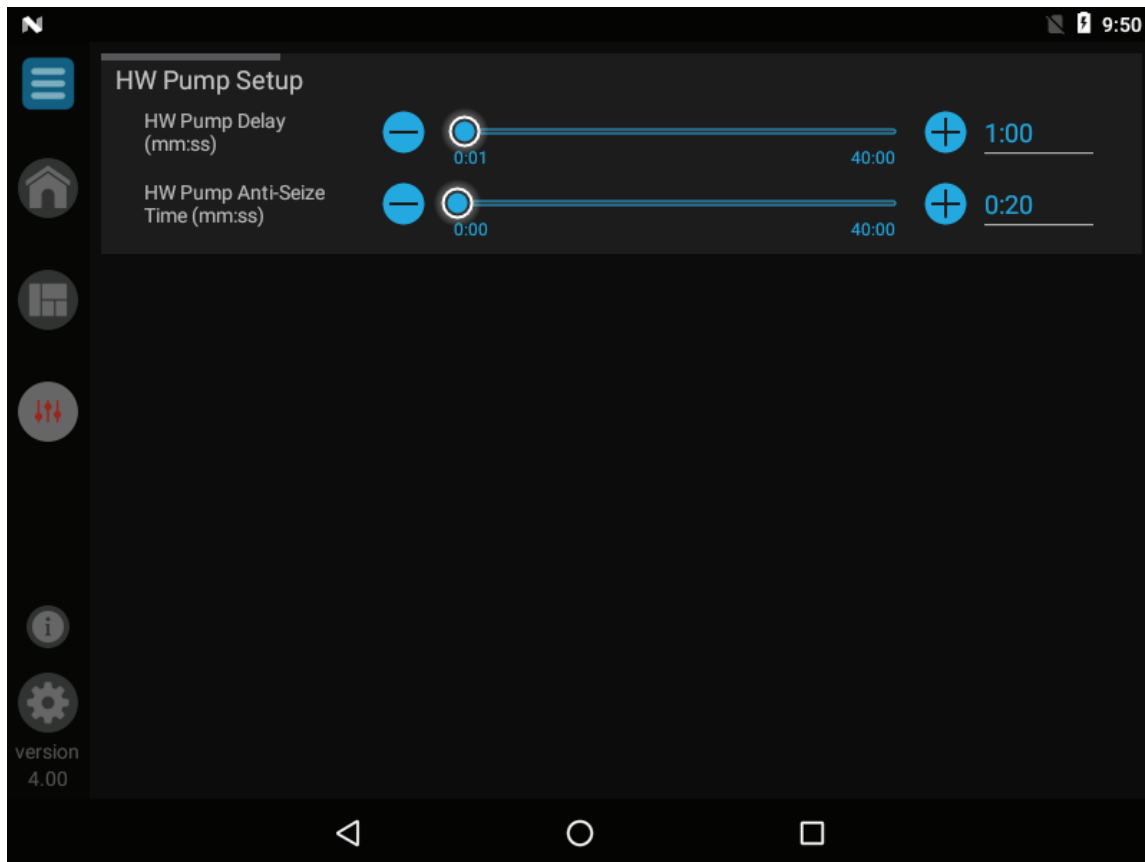

Table 1G Pumps (This table lists control module parameters; use the sub-tab under the Setup tab to access them.)

Menu	Parameter Name (as shown on the LCD screen)	Min	Max	Default
		Value	Value	Value
HW PUMP SETUP	HW Pump Delay	0.5	2400	30
	HW Pump Anti-Seize Time	0	40	0.33



# 1 Service *(continued)*

## **Pumps**

### **HW Pump Delay**

The HW pump delay parameter sets the length of time the HW pump will run after a HW demand has been satisfied. This parameter is adjustable by the installer by accessing the HW Pump Delay parameter.

### **HW Pump Anti-Seize Time**

If the appliance pump does not run for 24 hours, it will be turned on briefly to prevent it from seizing. The length of time it runs is determined HW Pump Anti-Seize Time.

# 1 Service

## Cascade Screens

Figure 1-10 Cascade Setup Screen

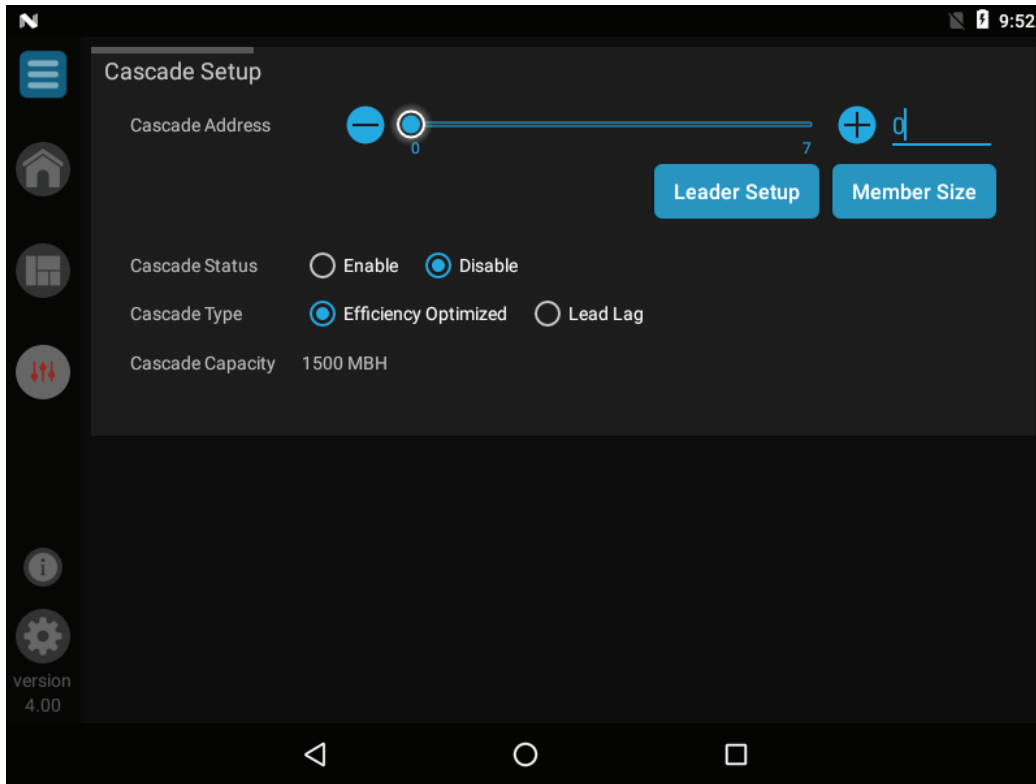
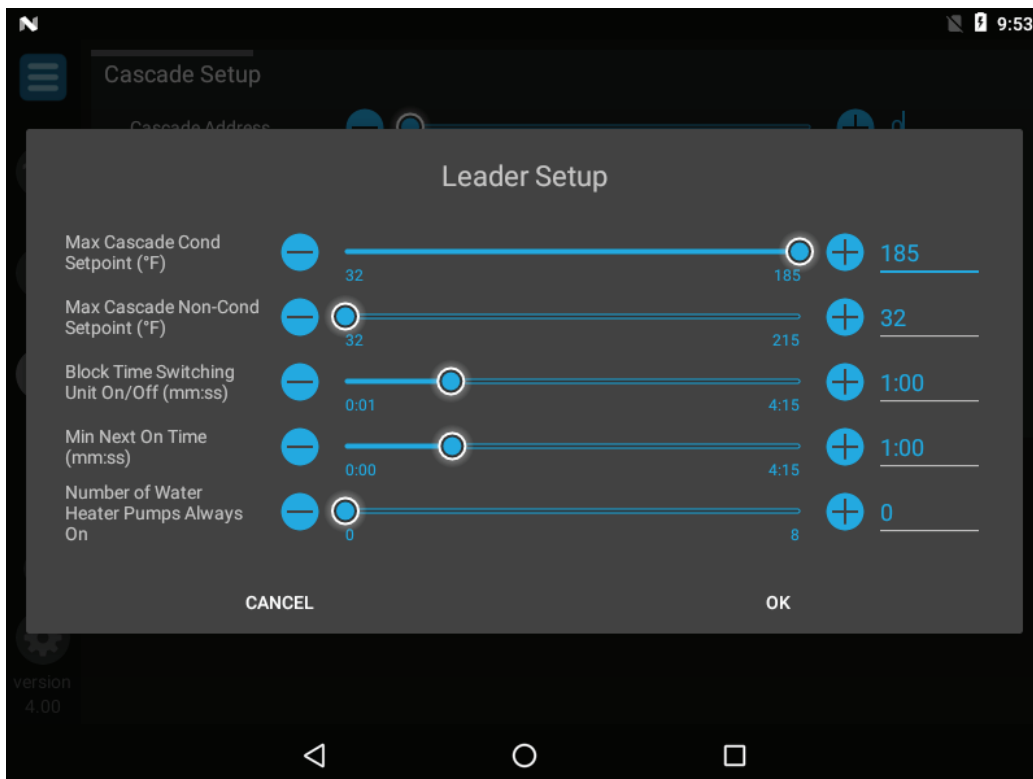

Figure 1-11 Cascade Leader Setup



# 1 Service *(continued)*

**Table 1H Cascade** (This table lists control module parameters; use the sub-tab under the Setup tab to access them.)

Menu	Parameter Name (as shown on the LCD screen)	Min	Max	Default
		Value	Value	Value
CASCADE	Cascade Address	0	7	1
	Cascade Status	ENABLE	DISABLE	DISABLE
	Cascade Type	N/A	N/A	N/A
	Max Cascade Cond Set point (F)	32	185	185
	Max Cascade Non-Cond Set point (F)	68	260	185
	Block Time Switching Water Heater On / Off	0	4:15	60
	Minimum Next On Time	0	4:15	60

## Cascade

### Cascade Address

The appliance designated as the Leader needs to be programmed with address 0. All the Member appliance(s) require addresses from 1 to 7, and the addresses must be different for each Member. The addresses can be in any order, regardless of the order in which the units are wired together. The tank sensor must be connected to the Leader appliance.

### Cascade Status

The appliance is part of a group of units sequenced together. The designated Leader unit determines the total output needed from the group based on the set point and controlling sensor reading. It assigns portions of the output to itself (Leader) and the Member units. When Cascade is active, each appliance in the group requires a unique address.

### Cascade Type

The two (2) types of Cascade control are listed below and on the next page:

#### *Efficiency Optimization*

This method is used when it is desired to have the most efficient system. When the first appliance reaches a certain rate (default = 80%), it lowers its rate to 40% and turns on the next appliance at 40%. The two (2) appliances then modulate at the same rate. As the calculated load increases further and both appliances ramp up to 80%, it lowers the rate of the first two (2) appliances to 53% and brings the next appliance on at 53%. The three (3) appliances then modulate together. As the calculated load decreases, the appliances will reach a lower threshold (default = 10%), at which time the last appliance (the third one in this example) will turn off and the Cascade will increase the rates of the remaining appliances to provide the equivalent total output as before ( $(3 \times 10\%) / 2 = 15\%$  in this example).

# 1 Service

## *L/L: Lead/Lag*

This method is used when it is desired to run the least number of appliances as possible. When the first appliance reaches 100% and calculated demand is still greater, the Cascade will bring on appliance number two. At the same time the first appliance will reduce its firing rate by an amount equal to the initial firing rate of the second appliance. As the calculated demand continues to increase, the first appliance will go to high fire, followed by ramping up the second appliance. If the calculated demand is still increasing once the second appliance reaches 100%, the Cascade will bring on appliance number three and reduce the firing rate of appliance number two by an amount equal to the initial firing rate of the third appliance.

This sequence will continue until the load is matched or all appliances are firing at 100%. When the load begins to decrease, the last appliance to fire will modulate down to low fire and hold there. As the calculated demand continues to decrease, the second to the last appliance will modulate down to low fire. If calculated demand is still decreasing, the last appliance will shut down and the next to the last appliance will increase its firing rate to make up the lost BTU's of the last appliance. If the calculated demand continues to decrease, it will modulate down to low fire and hold there while the next previous appliance starts to modulate down, as before. This will continue until either demand is matched or all appliances have shut down.

## **Maximum Cascade Cond / Non-Cond Set point (F)**

These types of parameters determine the set point used by the individual appliances in a Cascade, and they are accessible by pressing the Leader Setup button. When an appliance is commanded to fire by the Leader appliance, it will attempt to achieve this temperature at its outlet. If any of the appliance outlet temperatures reach the maximum cascade set point, the appliance will then modulate down on its own in order to keep its outlet temperature within the maximum cascade set point. Therefore, these parameters can be used to limit the outlet temperatures of all the appliances in a Cascade.

## **Blocking Time Switching Water Heater On / Off**

In order to prevent units in a Cascade from short cycling, this parameter defines the minimum ON and OFF time for each unit. The installer can adjust this time by accessing the Blocking Time Switching Water Heater On / Off parameter.

## **Minimum Next On Time**

In order to reduce the risk of temperature overshoot with a Cascade, this parameter defines the minimum time delay from starting one unit until the next unit may be started.

# 1 Service *(continued)*

## Service Screens

The Service Screen allows the integrated control to override all other heat demands and operate at high fire and low fire conditions. To place the appliance into Service Mode, press the START button. As specified above the integrated control will override all other heat demands, however, all safeties will be active. If no buttons are pressed, the integrated control will automatically revert back to its original status after the “Remaining time in Service” counter expires.

Once the appliance has been placed into Service Mode it will light and modulate to low fire. At any time after that point there are two (2) ways to adjust the firing rate. The first way is by pressing one of the two (2) preset buttons. The second way is by manually adjusting the firing percentage using the “+” and “-” buttons. When Service Mode is no longer needed press the STOP button to return to normal operation.

Figure 1-12 Service Maintenance



# 1 Service

Figure 1-13 Service Notification

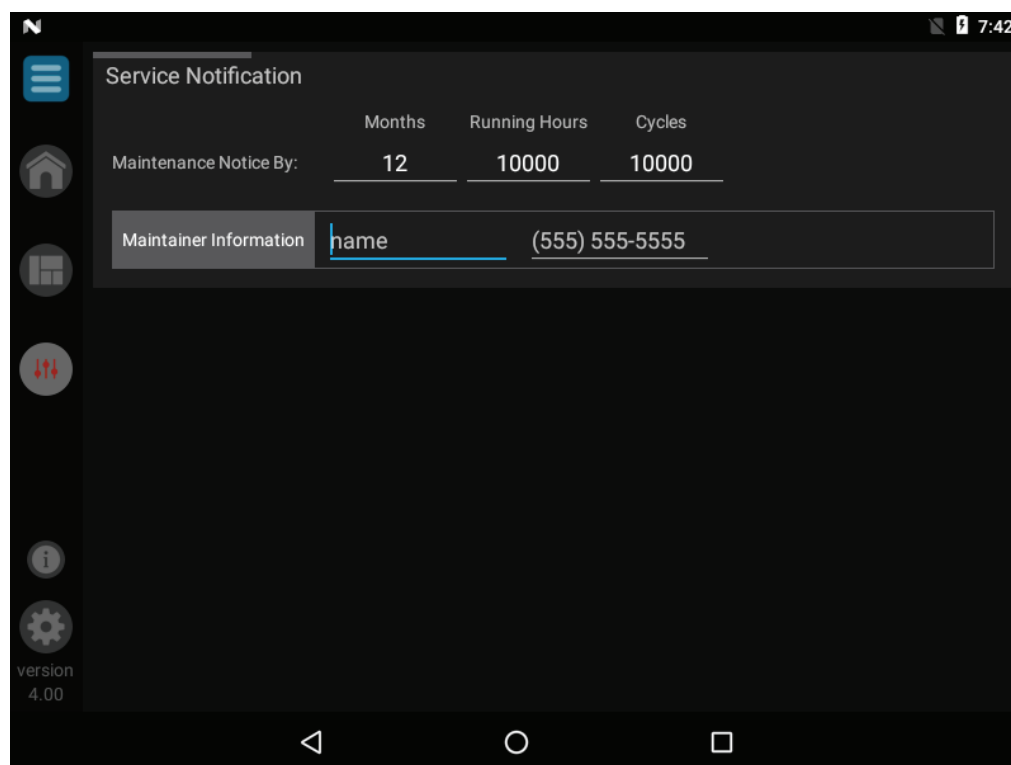

Table 11 Service Notification (This table lists control module parameters; use the sub-tab under the Setup tab to access them.)

Menu	Parameter Name (as shown on the LCD screen)	Min	Max	Default
		Value	Value	Value
SERVICE NOTIFICATION	Maintenance Notice By: Months	0	36	12
	Maintenance Notice By: Running Hours	0	100,000	10,000
	Maintenance Notice By: Cycles	0	100,000	10,000
	Maintainer Information: Name	N/A	N/A	N/A
	Maintainer Information: Phone	N/A	N/A	N/A

## Service

### Maintenance Notice By: Months

When the appliance control determines that a scheduled service is due based on the months of installation, the appliance display will turn yellow and a new status screen will appear informing the installer that maintenance is required.

### Maintenance Notice By: Running Hours

When the appliance control determines that a scheduled service is due based on the hours of actual operation, the appliance display will turn yellow and a new status screen will appear informing the installer that maintenance is required.

### Maintenance Notice By: Cycles

When the appliance control determines that a scheduled service is due based on the number of appliance cycles, the appliance display will turn yellow and a new status screen will appear informing the installer that maintenance is required.

### Maintainer Information: Name and Phone Number

When a Maintenance Reminder timer or counter has expired, a Maintenance Reminder screen will appear on the display. By programming the installer's name and phone number, this information will appear on the Maintenance Reminder Screen at that time. This can be programmed by accessing parameters I4 and L5. When selected, another menu will appear with PHONE and NAME. Note that the phone number is limited to 10 characters, and the name is limited to 26 characters. Only 0 - 9, A - Z (CAPS only), &, (,), +, and - are permitted.

# 1 Service *(continued)*

## Graph Screens

The Graph Screen consists of two (2) different types of screens: the Short Term Data Screen and the Long Term Data Screen. If a parameter is selected by mistake, it can be deselected by re-selecting the parameter. A maximum of eight (8) items can be graphed at one time.

Figure 1-14 Graph Select

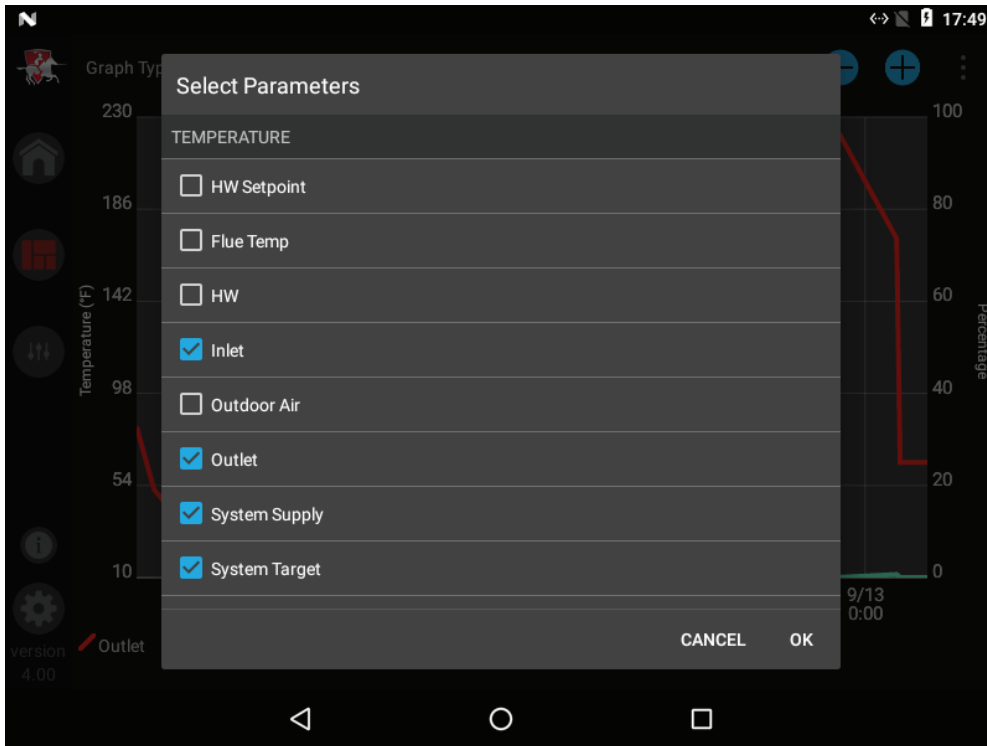

Once the items to be graphed are selected, press the OK button to view the graph. Each item graphed will have a different color line to represent it. The items selected will be shown below the graph along with their corresponding color.

Figure 1-15 Graph Screen

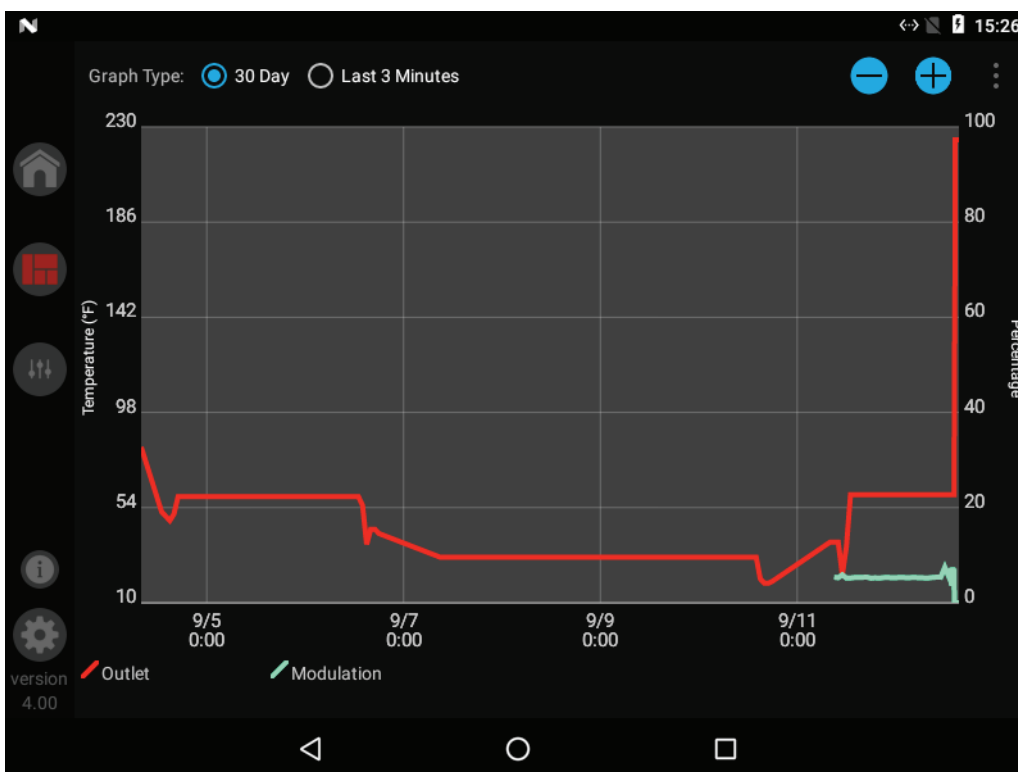

# 1 Service History Screen

The History Screen shows the status of various counters and faults. Within the History Screen there are two separate sections, the “Lockout Blocking Fault” and “Runtime History”.

The left side of the screen reflects the “Lockout Blocking Fault” section which allows you to view the last 20 lockout/blocking faults. Succeeded by each fault is the date and time of when the fault occurred. A three (3) minute graph of sensor data before the fault can be viewed by selecting the VIEW button.

The “Runtime History” section includes the following information:

- Power hours – Shows the number of hours the control has been powered on since the last reset.
  - Running hours – Shows the number of hours that the appliance has been firing since the last reset.
  - Ignition attempts – Shows the number of times the control has attempted to ignite since the last reset.
  - Successful ignition attempts - Shows the number of times the control has successfully ignited since the last reset.
  - Total power hours – Shows the total number of hours the control has been powered.
  - Total running hours – Shows the total number of hours that the appliance has been firing.
  - Total ignition attempts – Shows the total number of times the control has attempted to ignite.
  - Total successful ignition attempts – Shows the total number of times the control has successfully ignited.
- The top right of this screen details the running hours based on 4 different running percentages.

Figure 1-16 Fault History

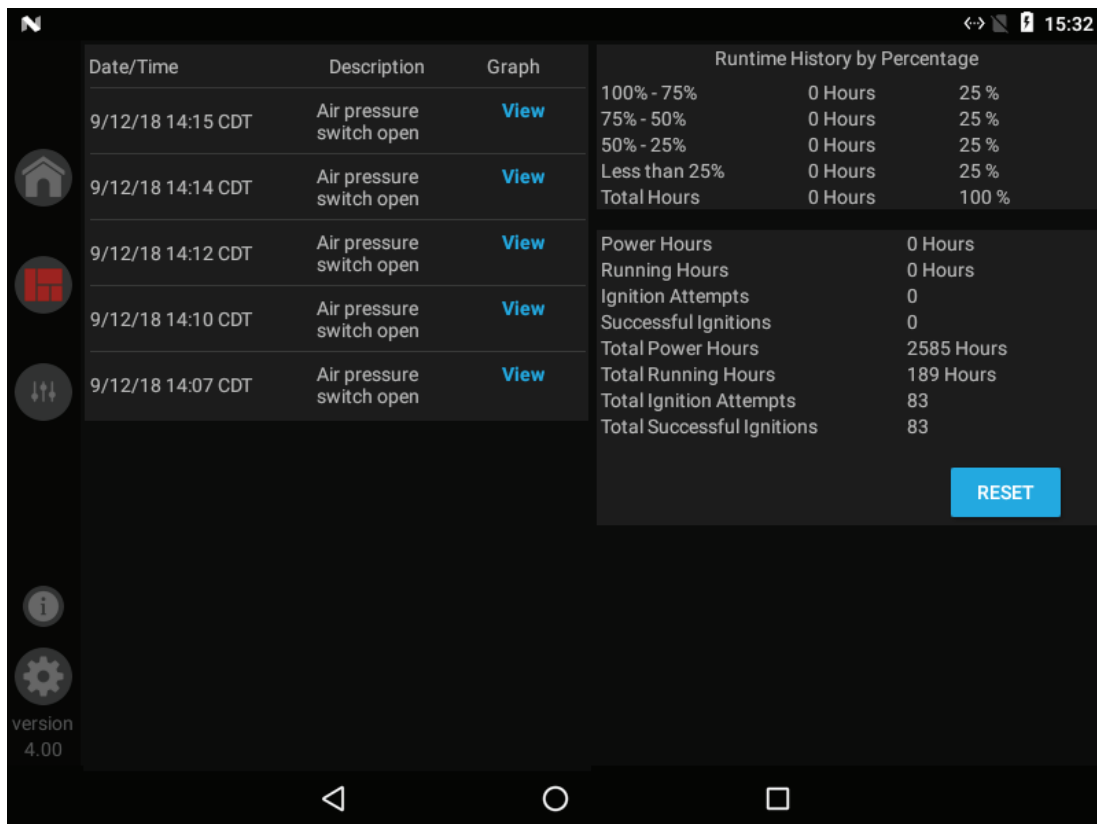



## 2 Maintenance

### Maintenance and annual startup

Table 2A Service and Maintenance Schedules

<b>Service technician</b> (see the following pages for instructions)		<b>Owner maintenance</b> (see the XP Plus User's Information Manual for instructions)	
<b>ANNUAL START-UP</b>	<p><b>General:</b></p> <ul style="list-style-type: none"> <li>• Address reported problems, if any</li> <li>• Inspect interior; clean and vacuum if necessary</li> <li>• Clean condensate trap and fill with fresh water</li> <li>• Check for leaks (water, gas, flue, condensate)</li> <li>• Verify flue and air lines in good condition and sealed tight</li> <li>• Check system water pressure/system piping/expansion tank</li> <li>• Check control settings</li> <li>• Check the ignition and both flame sense electrodes (sand off any deposits; clean and reposition)</li> <li>• Check wiring and connections</li> <li>• Perform start-up checkout and performance verification per Section 10 of the XP Plus Installation and Operation Manual.</li> <li>• Flame inspection (stable, uniform)</li> <li>• Check flame signal (at least 8 microamps at high fire)</li> <li>• Test low water cutoff.</li> </ul> <p><b>If combustion or performance indicate need:</b></p> <ul style="list-style-type: none"> <li>• Clean heat exchanger</li> <li>• Remove and clean burner using compressed air only</li> <li>• Clean the blower wheel</li> </ul>	<b>Daily</b>	<ul style="list-style-type: none"> <li>• Check appliance area</li> <li>• Check pressure/temperature gauge</li> </ul>
		<b>Monthly</b>	<ul style="list-style-type: none"> <li>• Check vent piping</li> <li>• Check air piping</li> <li>• Check air and vent termination screens</li> <li>• Check relief valve</li> <li>• Check condensate drain system</li> <li>• Check Delta T</li> <li>• Remove debris from Y-Strainer</li> </ul>
		<b>Every 6 months</b>	<ul style="list-style-type: none"> <li>• Test low water cutoff</li> <li>• Reset button (low water cutoff)</li> <li>• Check appliance piping (gas and water) for leaks</li> <li>• Operate relief valve</li> <li>• Check water chemistry</li> </ul>

## 2 Maintenance

### ⚠ WARNING

Follow the service and maintenance procedures given throughout this manual and in component literature shipped with the appliance. Failure to perform the service and maintenance could result in damage to the appliance or system. Failure to follow the directions in this manual and component literature could result in severe personal injury, death, or substantial property damage.

### ⚠ WARNING

The appliance should be inspected annually only by a qualified service technician. In addition, the maintenance and care of the appliance designated in Table 2A and explained on the following pages must be performed to assure maximum appliance efficiency and reliability. Failure to service and maintain the appliance and system could result in equipment failure.

### ⚠ WARNING

Electrical shock hazard – Turn off power to the appliance before any service operation on the appliance except as noted otherwise in this instruction manual. Failure to turn off electrical power could result in electrical shock, causing severe personal injury or death.

### Address reported problems

1. Inspect any problems reported by the owner and correct before proceeding.

### Inspect appliance area

1. Verify that appliance area is free of any combustible materials, gasoline, and other flammable vapors and liquids.
2. Verify that air intake area is free of any of the contaminants listed in Section 1 of the XP Plus Installation and Operation Manual. If any of these are present in the appliance intake air vicinity, they must be removed. If they cannot be removed, reinstall the air and vent lines per this manual.

### Inspect appliance interior

1. Remove the front access covers and inspect the interior of the appliance.
2. Vacuum any sediment from inside the appliance and components. Remove any obstructions.

### Clean condensate trap

1. Inspect the condensate drain line, vent line, condensate PVC fittings, and condensate trap.

### Flush condensate trap with water

1. Remove the four (4) screws securing the top cover to the condensate trap and remove the cover (FIG. 2-1).
2. Locate the plastic ball inside the float tube. Verify there is nothing under the ball causing it to not seat properly.
3. Fill with fresh water until the water begins to pour out of the drain.
4. Replace the top cover and the screws removed in Step 1.

Figure 2-1 Condensate Trap

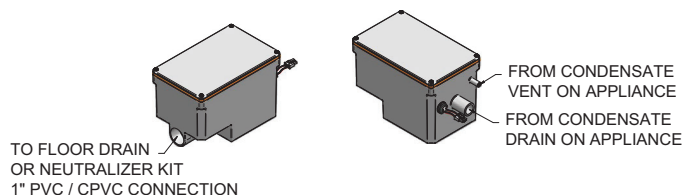

### Check all piping for leaks

1. Inspect all water and gas piping and verify to be leak free.
2. Look for signs of leaking lines and correct any problems found.
3. Check gas line using the procedure found in Section 7 - *Gas Connections* of the XP Plus Installation and Operation Manual.

### Flue vent system and air piping

1. Visually inspect the entire flue gas venting system and air piping for blockage, deterioration, or leakage. Repair any joints that show signs of leakage. Verify that air inlet pipe is connected and properly sealed.
2. Verify that appliance vent discharge and air intake are clean and free of obstructions.

### ⚠ WARNING

Failure to inspect for the above conditions and have them repaired can result in severe personal injury or death.

### Check water system

1. Verify all system components are correctly installed and operational.
2. Check the cold fill pressure for the system. Verify it is correct (must be a minimum of 12 PSI).
3. Watch the system pressure as the appliance heats up (during testing) to ensure pressure does not rise too high. Excessive pressure rise indicates expansion tank sizing or performance problem.
4. Inspect automatic air vents and air separators. Remove air vent caps and briefly push valve to flush vent. Replace caps. Make sure vents do not leak. Replace any leaking vents.

## 2 Maintenance *(continued)*

### Check expansion tank

1. Expansion tanks provide space for water to move in and out as the system water expands due to temperature increase or contracts as the water cools. Tanks may be open, closed, or diaphragm or bladder type. See the XP Plus Installation and Operation Manual for suggested best location of expansion tanks and air eliminators.

### Check appliance relief valve

1. Inspect the relief valve and lift the lever to verify flow. Before operating any relief valve, ensure that it is piped with its discharge in a safe area to avoid severe scald potential. Read Section 6 - System Piping before proceeding further.

#### **⚠ WARNING**

Safety relief valves should be re-inspected **AT LEAST ONCE EVERY THREE YEARS** by a licensed plumbing contractor or authorized inspection agency to ensure that the product has not been affected by corrosive water conditions and to ensure that the valve and discharge line have not been altered or tampered with illegally. Certain naturally occurring conditions may corrode the valve or its components over time, rendering the valve inoperative. Such conditions are not detectable unless the valve and its components are physically removed and inspected. This inspection must only be conducted by a plumbing contractor or authorized inspection agency – not by the owner. Failure to re-inspect the appliance relief valve as directed could result in unsafe pressure build-up, which can result in severe personal injury, death, or substantial property damage.

#### **⚠ WARNING**

Following installation, the valve lever must be operated **AT LEAST ONCE A YEAR** to ensure that waterways are clear. Certain naturally occurring mineral deposits may adhere to the valve, rendering it inoperative. When manually operating the lever, water will discharge and precautions must be taken to avoid contact with hot water and to avoid water damage. Before operating lever, check to see that a discharge line is connected to this valve directing the flow of hot water from the valve to a proper place of disposal. Otherwise severe personal injury may result. If no water flows, valve is inoperative. Shut down the appliance until a new relief valve has been installed.

2. After following the above warning directions, if the relief valve weeps or will not seat properly, replace the relief valve. Ensure that the reason for relief valve weeping is the valve and not over-pressurization of the system due to expansion tank waterlogging or undersizing.

### Inspect ignition and flame sense electrode

1. Remove the ignition and the flame sense electrode from the heat exchanger access cover.
2. Remove any deposits accumulated on the ignition/flame sense electrodes using sandpaper. If the electrodes cannot be cleaned satisfactorily, replace with new ones.
3. Replace ignition and flame sense electrode, making sure the gaskets are in good condition and correctly positioned.

### Check ignition ground wiring

1. Inspect appliance ground wire from the heat exchanger access cover to ground terminal strip.
2. Verify all wiring is in good condition and securely attached.
3. Check ground continuity of wiring using continuity meter.
4. Replace ground wires if ground continuity is not satisfactory.

### Check all appliance wiring

1. Inspect all appliance wiring, making sure wires are in good condition and securely attached.

### Check control settings

1. Navigate to the Setup Screen and check all settings. See Section 1 of this manual. Adjust settings if necessary. See Section 1 of this manual for adjustment procedures.
2. Check settings of external limit controls (if any) and adjust if necessary.

### Perform start-up and checks

1. Start appliance and perform checks and tests specified in Section 10 - *Start-up* of the XP Plus Installation and Operation Manual.

### Check burner flame

1. Inspect flame through observation windows.
2. If the flame is unsatisfactory at either high fire or low fire, remove and clean the burner. Clean the burner thoroughly using a vacuum cleaner or compressed air. Do not use compressed air to clean the burner if cleaning is performed inside a building.
  - Shut down the appliance:
    - Follow the “To Turn Off Gas to Appliance” instructions for the appliance in Section 10 - *Start-up* of the XP Plus Installation and Operation Manual.
    - Do not drain the appliance unless it will be exposed to freezing temperatures.
3. Allow time for the appliance to cool to room temperature if it has been firing.

## 2 Maintenance

4. Remove the front access panel.
5. Disconnect the wiring connections on the top of the combustion air blower.
6. Disconnect the gas piping at the union. Remove the four (4) bolts and nuts from the gas inlet flange to the side of the air / gas venturi. Carefully handle the cork gasket and set aside for re-use if not damaged.
7. Carefully remove the combustion blower and air / gas venturi.
8. Remove the blower transition.
9. Remove the burner.
10. Reassemble the unit in reverse order of component removal.

**⚠ CAUTION** Damaged gaskets and seals in the system can result in substantial property damage. Ensure that damaged or torn gaskets are replaced.

### Check flame signal

1. At high fire the flame signal shown on the display should be at least 8 microamps.
2. A lower flame signal may indicate a fouled or damaged flame sense electrode. If cleaning the flame sense electrodes does not improve, ground wiring is in good condition, and ground continuity is satisfactory, replace the flame sense electrode.
3. See Section 3 - *Troubleshooting* in this manual for other procedures to deal with low flame signal.

### Review with owner

1. Review the XP Plus User's Information Manual with the owner.
2. Emphasize the need to perform the maintenance schedule specified in the XP Plus User's Information Manual (and in this manual as well).
3. Remind the owner of the need to call a licensed contractor should the appliance or system exhibit any unusual behavior.
4. Remind the owner to follow the proper shutdown procedure and to schedule an annual start-up at the beginning of the next heating season.

### Cleaning heat exchanger

For recommended materials including brush, appropriate extension(s), refractory cover, and detailed instructions, see Table 12B - Heat Exchanger Cleaning Kit in the XP Plus Installation & Operation Manual.

1. Shut down appliance:
  - Follow the "To Turn Off Gas to Appliance" instructions for the appliance in Section 10 - *Start-up* of the XP Plus Installation and Operation Manual.
  - Do not drain the appliance unless it will be exposed to freezing temperatures.
2. Allow time for the appliance to cool to room temperature if it has been firing.
3. Remove the flex duct connecting the venturi to the air box. Remove the intake air flex duct.
4. Disconnect the gas train at the union and at the venturi. Loosen the gas train support bracket. Remove the gas train.

**⚠ WARNING** The appliance contains ceramic fiber materials. Use care when handling these materials per instructions in the XP Plus Service Manual. Failure to comply could result in severe personal injury.

5. Remove the bolts securing the heat exchanger access cover and set aside.
6. Slide out the heat exchanger door and blower assembly. Pull the pin to swing the door open.

**NOTE:** On some models, the front corner post may need to be removed in order to fully swing the heat exchanger door open. The corner post can be removed by loosening the two nuts at the base and the two screws at the top of the post.

7. Remove the condensate hose from the condensate trap. Connect a field supplied 1" diameter hose to a drain pan. Using field supplied means, cover the refractory in the back of the combustion chamber of the heat exchanger.
8. Use a vacuum cleaner to remove any accumulation on the appliance heating surfaces. Do not use any solvent.
9. Brush the heat exchanger while dry using a nylon bristle brush. **Caution:** DO NOT use a metal brush. Re-vacuum the heat exchanger.
10. Finish cleaning using a clean cloth dampened with warm water. Rinse out debris with a low pressure water supply.
11. Allow the heat exchanger to thoroughly dry.
12. Remove the field supplied rear refractory cover from the back of the combustion chamber of the heat exchanger and reassemble.
13. Close isolation valves on piping to isolate appliance from system. Attach a hose to the appliance drain and flush appliance thoroughly with clean water by using purging valves to allow water to flow through the water makeup line to the appliance.

## 2 Maintenance *(continued)*

14. Perform start-up and check-out procedures in the Check Flame and Combustion - Section 10 - *Start-up* of the XP Plus Installation and Operation Manual.
15. Replace the access cover and restore appliance to operation.

**Figure 2-2** Location of the Heat Exchanger Inside Jacket

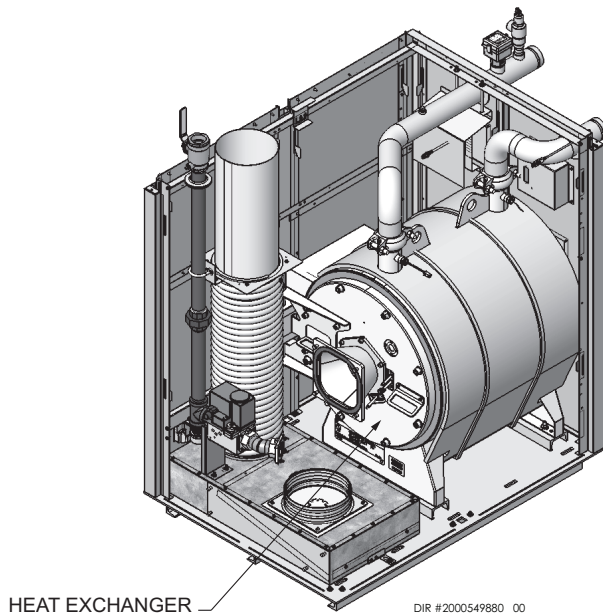

### Test low water flow conditions

#### NOTICE

This test is to be carried out once the XP Plus appliance is completely piped in with adequate gas and water flow. Once the test is completed, ensure that the isolation valve is opened up to allow full water flow.

#### Test procedure

1. Place the unit into Service Mode. Navigate to the Service Screen from the Home Screen by pressing the SETUP button and then the SERVICE MAINTENANCE MENU button.
2. On the Service Maintenance Screen, place heater into Service Mode by selecting the START button. In Service Mode, the appliance will fire at ignition speed and will then modulate to low fire.
3. Allow the unit to progress through its normal diagnostics and pre-purge programming.
4. Allow the unit to fire and operate until the temperatures stabilize. This occurs when the inlet and outlet temperatures are rising together and the Delta T ( $\Delta T$ ) is maintained.
5. When the unit stabilizes, begin to slowly shut off the isolation valve on the outlet piping of the appliance (see FIG. 2-3). This will begin to restrict the flow and simulate a low flow condition.
6. While slowly shutting off the isolation valve, refer to the Status Screen to watch the behavior of the appliance. This screen allows you to monitor the inlet temperature, outlet temperature, and  $\Delta T$ .
7. When the  $\Delta T$  reaches 30°F, the control will attempt to modulate the firing rate down to protect it from low flow conditions.
8. When the  $\Delta T$  reaches 35°F, the control module will turn off the burner. If the control module shuts down, the test was successful.
9. Completely open the isolation valve on the outlet piping of the appliance.
10. Resume operation.

**Figure 2-3** Adjust outlet isolation valve

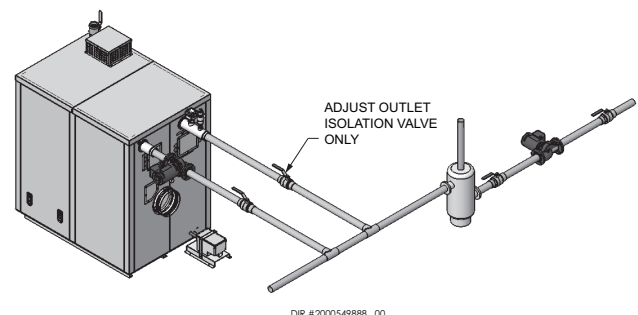

## 3 Troubleshooting

### ⚠ WARNING

Label all wires prior to disconnection when servicing controls. Wiring errors can cause improper and dangerous operation. Always disconnect power to the appliance before servicing. Failure to comply could result in severe personal injury, death, or substantial property damage.

### ⚠ WARNING

Never jumper (bypass) any device except for momentary testing as outlined in the Troubleshooting chart. Severe personal injury, death, or substantial property damage can result.

### Before troubleshooting:

- Have the following items:
  - Voltmeter that can check 480 VAC - 24 VAC, and 12 VDC
  - Continuity checker
  - Contact thermometer
- Check for voltage (Models 1250/1500 - 120 VAC, Models 2000/3000 - 208 VAC, and Model 4000 - 480 VAC) to the appliance.
- Make sure thermostat is calling for heat and contacts are closed. Check for 24 VAC between enable input and ground.
- Make sure all external limit controls are installed and operating.

### Check the following:

- Wire connectors to control module are securely plugged in at the module and originating control.
- Gas pressures:
  - Maximum: 14 inches w.c. (3.5 kPa) (natural and LP) with no flow (lock-up) or with appliance on
  - Minimum: 4 inches w.c. (1.0 kPa) (natural), and 8 inches w.c. (2.0 kPa) (LP), with gas flowing (verify during appliance start-up)
  - Pressure Drop: Maximum 1" w.c. from static (off) to dynamic (high fire)

### Check control module fuses

#### NOTICE

ALWAYS check control module fuses before replacing control module or any major components (blower, etc.). If one of these fuses is blown, it can prevent the control module or other components from operating.

- Turn OFF the power to the appliance at the external line switch.
- Remove the front access panel.
- Remove the two (2) screws securing the control panel cover to gain access to the control module.
- Inspect fuses F2, F4, and F5, see FIG 3-1 below.

Figure 3-1 Control Module Fuses

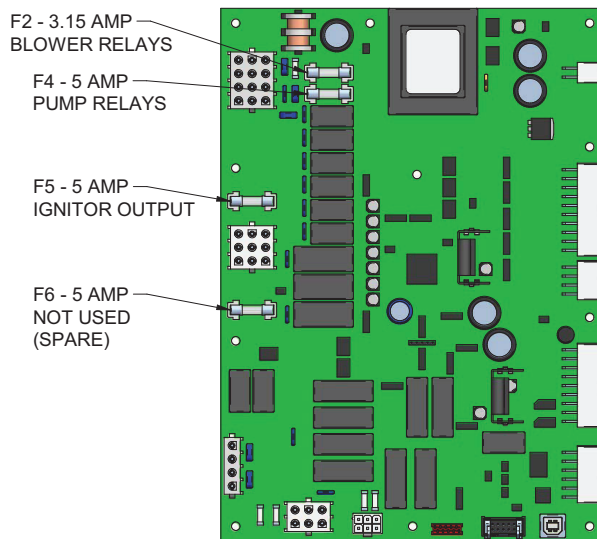

- The appliance is shipped with four (4) spare fuses in a plastic bag located inside the control panel.
- If necessary, replace open fuse (F2 is 3.15 amps, F4, F5, and F6 are 5 amps each).

**NOTE:** Fuses F2, F4, F5, and F6 are all slow blow fuses.

### ⚠ WARNING

Do not jumper fuse or replace with any fuse except as specified. Failure to comply could result in severe personal injury, death, or substantial property damage.

- Re-install the control panel cover using the two (2) screws removed in Step 3. Re-install the front access panel.
- Restore power to the appliance at the external line switch and verify appliance operation (Section 10 - *Start-up* in the XP Plus Installation and Operation Manual) after completing appliance service.

### 3 Troubleshooting *(continued)*

**Table 3A Troubleshooting Chart - No Display**

FAULT	CAUSE	CORRECTIVE ACTION
<b>No Display</b>	<ul style="list-style-type: none"> <li>- No power supplied to the unit.</li> <li>- No LED's illuminated on the Interface control board.</li> </ul>	<ul style="list-style-type: none"> <li>• Check external line switch, fuse, or breaker.</li> <li>• Check position of ON/OFF switch. Turn switch to the ON position.</li> <li>• Check supply voltage through the ON/OFF switch.</li> <li>• Check wiring harness connection between display board and Interface control board. Connect harness at both points.</li> </ul>
	<ul style="list-style-type: none"> <li>- Bad display, no LED's illuminated.</li> </ul>	<ul style="list-style-type: none"> <li>• Check connection.</li> </ul>
	<ul style="list-style-type: none"> <li>- Bad display.</li> </ul>	<ul style="list-style-type: none"> <li>• Replace the display.</li> </ul>
<b>No Burner Operation</b>	<ul style="list-style-type: none"> <li>- Main control board temperature set point satisfied.</li> </ul>	<ul style="list-style-type: none"> <li>• Review temperature setting.</li> </ul>
	<ul style="list-style-type: none"> <li>- Tank thermostat satisfied.</li> </ul>	<ul style="list-style-type: none"> <li>• Review tank thermostat setting.</li> </ul>
	<ul style="list-style-type: none"> <li>- Unit locked out on fault.</li> </ul>	<ul style="list-style-type: none"> <li>• Consult display for specific fault. Refer to fault descriptions on page 42 of this manual for corrective actions.</li> </ul>
<b>Unit Does Not Modulate Up to 100%</b>	<ul style="list-style-type: none"> <li>- Ramp delay active.</li> </ul>	<ul style="list-style-type: none"> <li>• Check ramp delay parameter settings.</li> </ul>
		<ul style="list-style-type: none"> <li>• Turn ramp delay feature off. See pages 16-17 of this manual for instructions on how to turn this feature off.</li> </ul>
	<ul style="list-style-type: none"> <li>- Appliance controlled by BMS.</li> </ul>	<ul style="list-style-type: none"> <li>• Check BMS parameter settings.</li> </ul>

# 3 Troubleshooting

## Checking temperature sensors

The appliance temperature sensors (inlet water, outlet water, tank, and flue) are all resistance type devices. The following tables show the correct values for the sensors at various temperatures. Use an ohmmeter to read the resistance of the sensor at a known temperature. If the resistance of the sensor does not closely match its corresponding table, replace the sensor.

It is important to note that the outlet water sensors have two temperature sensing devices in one housing. These devices are designated as S1/S9 - outlet sensor and S3/S10 - flue sensor. Please reference the wiring diagram in the XP Plus Installation and Operation Manual for correct terminal location.

**Table 3B - Inlet Water/Tank Sensor Resistance vs. Temperature**

Temperature	Resistance	Temperature	Resistance
50	18,780	158	1,990
68	12,263	176	1,458
86	8,194	194	1,084
104	5,592	212	817
122	3,893		
140	2,760		

**Table 3C - Outlet Water Sensor Resistance vs. Temperature**

Outlet	S1	R/Y		Outlet	S9	RW/Y	
Temperature	Resistance	Temperature	Resistance	Temperature	Resistance	Temperature	Resistance
50	19,553	158	2,004	50	40,030	158	3,478
68	12,690	176	1,464	68	25,030	176	2,492
86	8,406	194	1,084	86	16,090	194	1,816
104	5,715	212	816	104	10,610	212	1,344
122	3,958			122	7,166		
140	2,786			140	4,943		

**Table 3D - Flue Sensor Resistance vs. Temperature**

Temperature	Resistance	Temperature	Resistance
68	14,773	176	1,707
86	9,804	194	1,266
104	6,652	212	952
122	4,607	230	726
140	3,252	248	560
158	2,337	--	--

**Table 3E - Inlet/Outlet and Tank Sensor Resistance vs. Temperature**

Temperature	Resistance	Temperature	Resistance
50	18,780	158	1,990
68	12,263	176	1,458
86	8,194	194	1,084
104	5,592	212	817
122	3,893	--	--
140	2,760	--	--



### 3 Troubleshooting *(continued)*

**Table 3F Troubleshooting Chart - Noisy System**

FAULT	CAUSE	CORRECTIVE ACTION
<b>Noisy Operation</b>	- Supply gas problem. Natural gas pressures should be between 4 - 14 inches w.c. (1.0 - 3.5 kPa) and LP gas pressures should be between 8 - 14 inches w.c. (2.0 - 3.5 kPa).	<ul style="list-style-type: none"> <li>Refer to Section 7 - Gas Connections of the XP Plus Installation and Operation Manual for detailed information concerning the gas supply.</li> </ul>
	- Gas/air mixture problem.	<ul style="list-style-type: none"> <li>Refer to the Gas Valve Adjustment Procedure on page 52 of this manual for the proper gas valve setting. Verify that the vent/air intake lengths do not exceed the maximum listed in the General Venting section of the XP Plus Installation and Operation Manual.</li> </ul>
	- Dirty/damaged burner.	<ul style="list-style-type: none"> <li>Refer to pages 35 - 36 in this manual for the burner removal and inspection procedure. Clean or replace the burner as necessary.</li> </ul>
	- Air in the piping system.	<ul style="list-style-type: none"> <li>Properly purge all air from the piping system.</li> </ul>
<b>No Pump Operation - Appliance Pump System Pump or HW Pump</b>	- Blown fuse.	<ul style="list-style-type: none"> <li>Replace fuse F4 on the control board, see page 38 of this manual.</li> </ul>
	- Faulty pump.	<ul style="list-style-type: none"> <li>Replace pump.</li> </ul>
	- Internal fault on control board.	<ul style="list-style-type: none"> <li>Replace main control board.</li> </ul>
	- Faulty pump relay.	<ul style="list-style-type: none"> <li>Replace relay.</li> </ul>
<b>Relief Valve Opening</b>	- System pressure exceeds relief valve setting.	<ul style="list-style-type: none"> <li>Lower the system pressure below the rating of the supplied relief valve or replace the standard relief valve with a higher rated valve up to the maximum pressure of the heat exchanger 160 psi (40 kPa).</li> <li>Improperly sized expansion tank.</li> </ul>

# 3 Troubleshooting

**Table 3G** Troubleshooting Chart - Fault Messages Displayed on Appliance Interface

FAULT	DESCRIPTION	CORRECTIVE ACTION
<p><b>Gas Pressure SW Open</b> (will require a manual reset once the condition has been corrected. Press the RESET button on the display to reset.)</p>	<p>Either the low gas pressure switch or the high gas pressure switch tripped.</p>	<ul style="list-style-type: none"> <li>• Measure the supply gas pressure to determine cause of failure. Natural gas pressures should be between 4 - 14 inches w.c. (1.0 - 3.5 kPa) and LP gas pressures should be between 8 - 14 inches w.c. (2.0 - 3.5 kPa).</li> <li>• Refer to Section 7 - Gas Connections of the XP Plus Installation and Operation Manual for detailed information concerning the gas supply.</li> <li>• Correct the supply gas pressure if necessary.</li> </ul>
<p><b>Low Water Cutoff Open</b> (will require a manual reset once condition has been corrected. Press the RESET button on the display to reset.)</p>	<p>The low water cutoff is not making.</p>	<ul style="list-style-type: none"> <li>• Reset the LWCO from the RESET button inside the control panel box.</li> <li>• Verify system is full of water and all air has been purged from the system.</li> <li>• Check for loose or misplaced jumpers if flow switch or LWCO is not installed.</li> </ul>
	<p>Blown fuse.</p>	<ul style="list-style-type: none"> <li>• Replace fuse F2 on the control board, see page 38 of this manual.</li> </ul>
<p><b>Blocked Drain SW Open</b> (will require a manual reset once condition has been corrected. Press the RESET button on the display to reset.)</p>	<p>The blocked drain switch has detected excessive condensate build-up inside the unit.</p>	<ul style="list-style-type: none"> <li>• Check condensate tube from unit to floor drain for proper installation and obstructions.</li> <li>• Inspect condensate trap for blockage. Clean if necessary.</li> <li>• Check for loose wiring connection at wire harness plug.</li> <li>• Bad blocked drain switch. Replace switch.</li> </ul>
<p><b>APS Open</b> (will require a manual reset once the condition has been corrected. Press the RESET button on the display to reset.)</p>	<p>Blocked flue/air inlet pressure switch contacts are open.</p>	<ul style="list-style-type: none"> <li>• Check the wiring connections to switch. Wires should be connected to the common and normally closed terminals.</li> <li>• Vent/air intake lengths exceed the maximum allowed lengths. Refer to Section 3 - General Venting of the XP Plus Installation and Operation Manual for proper lengths.</li> <li>• Check for obstruction or blockage in the vent/air intake pipes or at terminations.</li> <li>• Check reference hose and tubing connected to the pressure switch for blockage or obstruction.</li> <li>• Inspect the burner. Reference pages 35 - 36 of this manual for removal and cleaning procedures. Replace if necessary.</li> <li>• Inspect the heat exchanger. Reference page 36 of this manual for removal and cleaning procedures. Replace if necessary.</li> <li>• Faulty air pressure switch. Replace switch.</li> </ul>

### 3 Troubleshooting *(continued)*

**Table 3G** (continued from previous page) *Troubleshooting Chart - Fault Messages Displayed on Appliance Interface*

FAULT	DESCRIPTION	CORRECTIVE ACTION
<p><b>Anti-cycling</b></p>	<p>The main control board has received a call for heat too quickly after the previous call for heat has ended.</p>	<ul style="list-style-type: none"> <li>• The control board will release the call for heat after a set time period.</li> <li>• The control board will release the call for heat if the outlet temperature drops too quickly.</li> </ul>
<p><b>Flame Failure Ignition</b> (will require a manual reset once the condition has been corrected. Press the RESET button on the display to reset.)</p>	<p>The unit has failed to prove main burner ignition. It will require a manual reset before attempting to fire again.</p>	<ul style="list-style-type: none"> <li>• Inspect spark electrode and associated wiring for damage and connection. Reference page 35 of this manual for removal and cleaning procedures. Replace if necessary.</li> <li>• Visually check for presence of a spark from the view port.</li> <li>• Check for proper electrical grounding of the unit.</li> <li>• Check incoming supply gas pressure. Natural gas pressures should be between 4 - 14 inches w.c. (1.0 - 3.5 kPa) and LP gas pressures should be between 8 - 14 inches w.c. (2.0 - 3.5 kPa). Refer to Section 7 - Gas Connections of the XP Plus Installation and Operation Manual for detailed information concerning the gas supply.</li> <li>• Verify that the plastic hose from the gas valve to the air/gas venturi is connected and is not damaged.</li> <li>• Verify that the vent/air intake pipes are correctly installed and that there are no obstructions.</li> <li>• If 120 VAC is present at the main control board, check the wiring between the main control board and the gas valve. Replace the wiring if necessary. Do not disconnect the wiring from the gas valve and attempt to measure voltage at that point. The main control board can detect if the gas valve is not connected and will display the Gas Valve / Connection fault.</li> <li>• If 120 VAC is present, check the outlet of the valve to ensure the valve is flowing gas. With a manometer connected to the outlet tap of the gas valve, when the unit is in the prepurge period, there should be a negative pressure present. When the valve is energized a change in pressure should occur. If the pressure change does not occur, the gas valve is not opening. Replace the gas valve.</li> <li>• Inspect flame sensor and associated wiring. Reference page 35 of this manual for removal and cleaning procedures. Replace if necessary.</li> <li>• Inspect the burner. Reference pages 35 - 36 of this manual for removal and cleaning procedures. Replace if necessary.</li> </ul>

### 3 Troubleshooting

**Table 3G** (continued from previous page) *Troubleshooting Chart - Fault Messages Displayed on Appliance Interface*

FAULT	DESCRIPTION	CORRECTIVE ACTION
<p><b>Flame Out of Sequence</b> (will require a manual reset once the condition has been corrected. Press the RESET button on the display to reset.)</p>	<p>The flame detector circuit is seeing a flame signal while no flame is present.</p>	<ul style="list-style-type: none"> <li>• Check supply voltage for proper polarity.</li> <li>• Check external wiring for voltage feedback.</li> <li>• Check the internal wiring for bad connections.</li> </ul>
<p><b>Flame Failure Running</b> (will require a manual reset once the condition has been corrected. Press the RESET button on the display to reset.)</p>	<p>The unit was running and lost the flame signal.</p>	<ul style="list-style-type: none"> <li>• Inspect flame rod and associated wiring for damage and connection. Reference page 35 of this manual for removal and cleaning procedures. Replace if necessary.</li> <li>• Check for proper electrical grounding of unit.</li> <li>• Check incoming supply gas pressure. Natural gas pressures should be between 4 - 14 inches w.c. (1.0 - 3.5 kPa) and LP gas pressures should be between 8 - 14 inches w.c. (2.0 - 3.5 kPa). Refer to Section 7 - Gas Connections of the XP Plus Installation and Operation Manual for detailed information concerning the gas supply.</li> <li>• Verify that the plastic hose from the gas valve to the air/gas venturi is connected and is not damaged.</li> <li>• Verify that the vent/air intake pipes are installed correctly and there are no obstructions.</li> <li>• Inspect flame sensor and associated wiring. Reference page 35 of this manual for removal and cleaning procedures. Replace if necessary.</li> <li>• Check combustion.</li> <li>• Inspect the burner. Reference pages 35 - 36 of this manual for removal and cleaning procedures. Replace if necessary.</li> </ul>
<p><b>Gas Valve / Relay Failure</b> (will require a manual reset once the condition has been corrected. Press the RESET button on the display to reset.)</p>	<p>The main control board did not detect the gas valve.</p>	<ul style="list-style-type: none"> <li>• Check wiring harness connection at the gas valve and at the main control board.</li> <li>• Replace the gas valve wire harness.</li> <li>• Replace the gas valve.</li> </ul>

### 3 Troubleshooting *(continued)*

**Table 3G** *(continued from previous page) Troubleshooting Chart - Fault Messages Displayed on Appliance Interface*

FAULT	DESCRIPTION	CORRECTIVE ACTION
<p><b>Auto Reset High Limit</b></p>	<p>The outlet water temperature has exceeded the setting of the automatic reset high limit.</p>	<ul style="list-style-type: none"> <li>• Verify that the system is full of water and that all air has been properly purged from the system.</li> <li>• Verify that the appliance is piped properly into the heating system. Refer to Section 6 - System Piping of the XP Plus Installation and Operation Manual for the proper piping methods for the XP Plus water heater.</li> <li>• Check 120 VAC to appliance pump motor on a call for heat. If voltage is not present, check wiring back to the main control board.</li> <li>• If 120 VAC is present on a call for heat and the water heater pump is not operating, replace the pump.</li> <li>• Check temperature setting of the main control board.</li> <li>• Check resistance of water sensors and compare to Table 3B on page 40 of this manual. Replace sensor if necessary.</li> <li>• Replace the main control board.</li> </ul>
<p><b>Manual Reset High Limit Open</b> (will require a manual reset once the condition has been corrected. Press the RESET button on the display to reset.)</p>	<p>The outlet water temperature has exceeded the setting of the high limit.</p>	<ul style="list-style-type: none"> <li>• Verify that the system is full of water and that all air has been properly purged from the system.</li> <li>• Verify that the appliance is piped properly into the heating system. Refer to Section 6 - System Piping of the XP Plus Installation and Operation Manual for the proper piping methods for the XP Plus appliance.</li> <li>• Check voltage to appliance pump motor on a call for heat. If voltage is not present, check wiring back to the main control board.</li> <li>• Replace the pump relay if necessary.</li> <li>• If 120 VAC is present on a call for heat and the water heater pump is not operating, replace the pump.</li> <li>• If the high limit has tripped, check setting of the device and the MRHL set point.</li> <li>• Check resistance of water sensors and compare to Table 3B on page 40 of this manual. Replace sensor if necessary.</li> <li>• Replace high limit (if equipped).</li> <li>• Replace main control board.</li> </ul>

### 3 Troubleshooting

**Table 3G** (continued from previous page) Troubleshooting Chart - Fault Messages Displayed on Appliance Interface

FAULT	DESCRIPTION	CORRECTIVE ACTION
<p><b>Fan Speed Low</b> (will require a manual reset once the condition has been corrected. Press the RESET button on the display to reset.)</p>	<p>The actual fan RPM is 30% lower than what is being called for.</p>	<ul style="list-style-type: none"> <li>• Vent/air intake lengths exceed the maximum allowed lengths. Refer to Section 3 - General Venting of the XP Plus Installation and Operation Manual for proper lengths.</li> <li>• Check for obstruction or blockage in the vent/air intake pipes or at terminations.</li> <li>• Check the wiring connections at the fan and at the main control board.</li> <li>• Replace the fan.</li> </ul>
	<p>Blown fuse.</p>	<ul style="list-style-type: none"> <li>• Replace fuse F2 on the control board, see page 38 of this manual.</li> </ul>
<p><b>Fan Speed High</b> (will require a manual reset once the condition has been corrected. Press the RESET button on the display to reset.)</p>	<p>The actual fan RPM is 30% higher than what is being called for.</p>	<ul style="list-style-type: none"> <li>• Vent/air intake lengths exceed the maximum allowed lengths. Refer to Section 3 - General Venting of the XP Plus Installation and Operation Manual for proper lengths.</li> <li>• Check for obstruction or blockage in the vent/air intake pipes or at terminations.</li> <li>• Check the wiring connections at the fan and at the main control board.</li> <li>• Replace the fan.</li> </ul>
<p><b>Louver Proving Sw Open</b></p>	<p>An optional remote proving switch is not making.</p>	<ul style="list-style-type: none"> <li>• Check function of remote devices.</li> <li>• Check for loose or misplaced jumper if proving switch is not installed.</li> </ul>
<p><b>Flue Temp High</b></p>	<p>The stack temperature has exceeded the set parameters for the appliance.</p>	<ul style="list-style-type: none"> <li>• Inspect the heat exchanger. Reference page 36 of this manual for the procedure on how to clean the flue side of the heat exchanger.</li> <li>• Inspect the flue sensor and associated wiring. Measure the resistance of the flue sensor and compare to Table 3D on page 40 of this manual. Replace the sensor if necessary.</li> <li>• Verify that the vent/air intake pipes are properly installed and that there are no obstructions.</li> </ul>

### 3 Troubleshooting *(continued)*

**Table 3G** *(continued from previous page)* Troubleshooting Chart - Fault Messages Displayed on Appliance Interface

FAULT	DESCRIPTION	CORRECTIVE ACTION
<p><b>Delta T High</b></p>	<p>The temperature rise across the heat exchanger has exceeded the set parameters for the appliance.</p>	<ul style="list-style-type: none"> <li>• Verify that the system is full of water and that all air has been properly purged from the system.</li> <li>• Verify that the appliance is piped properly into the heating system. Refer to Section 6 - System Piping of the XP Plus Installation and Operation Manual for the proper piping methods for the XP Plus appliance.</li> <li>• Check for 120 VAC to the appliance pump motor on a call for heat. If voltage is not present, check the wiring back to the main control board. Replace the main control board if necessary.</li> <li>• If 120 VAC is present on a call for heat and the water heater pump is not operating, replace the pump.</li> <li>• Verify that the appliance pump is the proper size. Reference Section 6 - System Piping of the XP Plus Installation and Operation Manual for appliance pump specifications.</li> <li>• Inspect the inlet and outlet sensors and associated wiring. Measure the resistance of the sensors and compare to the tables on page 40 of this manual.</li> </ul>
<p><b>Outlet Temp High</b></p>	<p>Outlet water temperature has exceeded the maximum outlet water temperature.</p>	<ul style="list-style-type: none"> <li>• Verify that the system is full of water and that all air has been properly purged from the system.</li> <li>• Verify that the appliance is piped properly into the heating system. Refer to Section 6 - System Piping of the XP Plus Installation and Operation Manual for the proper piping methods for the XP Plus appliance.</li> <li>• Check for 120 VAC to the appliance pump motor on a call for heat. If voltage is not present, check wiring back to the main control board. Replace the main control board if necessary.</li> <li>• If 120 VAC is present on a call for heat and the water heater pump is not operating, replace the pump.</li> <li>• Verify that the appliance pump is the proper size. Reference Section 6 - System Piping of the XP Plus Installation and Operation Manual for appliance pump specifications.</li> <li>• Inspect the outlet sensors and associated wiring. Measure the resistance of the sensors and compare to the tables on page 40 of this manual.</li> </ul>

### 3 Troubleshooting

**Table 3G** (continued from previous page) Troubleshooting Chart - Fault Messages Displayed on Appliance Interface

FAULT	DESCRIPTION	CORRECTIVE ACTION
<p><b>Rem Ctrl Flt</b></p>	<p>External control is cycling too often.</p>	<ul style="list-style-type: none"> <li>• Check set point of the external control.</li> <li>• Check the wiring between the external control and the unit.</li> <li>• Replace the control.</li> </ul>
<p><b>Parameters Saved</b> (will require a manual reset once the condition has been corrected. Press the RESET button on the display to reset.)</p>	<p>After downloading parameters from a laptop, the main control board must be reset.</p>	<ul style="list-style-type: none"> <li>• Press the RESET button on the display panel.</li> </ul>
<p><b>Service Blk</b></p>	<p>While the unit is in Service Mode, the outlet temperature has exceeded 185°F.</p>	<ul style="list-style-type: none"> <li>• Establish a heating load to remove the heat from the appliance loop.</li> <li>• Verify that the system is full of water and that all air has been properly purged from the system.</li> <li>• Verify that the appliance is piped properly into the heating system. Refer to Section 6 - System Piping of the XP Plus Installation and Operation Manual for the proper piping methods for the XP Plus appliance.</li> <li>• Check 120 VAC to the appliance pump motor on a call for heat. If voltage is not present, check the wiring back to the main control board. Replace the main control board if necessary.</li> <li>• If 120 VAC is present on a call for heat and the water heater pump is not operating, replace the pump.</li> <li>• Verify that the appliance pump is the proper size. Reference Section 6 - System Piping of the XP Plus Installation and Operation Manual for appliance pump specifications.</li> </ul>
<p><b>Sensor Open</b> (will require a manual reset once the condition has been corrected. Press the RESET button on the display to reset.)</p>	<p>Either the inlet water or outlet water temperature sensor has been disconnected.</p>	<ul style="list-style-type: none"> <li>• Check the sensors and their associated wiring. Repair or replace the sensor or wiring if damaged.</li> <li>• Measure the resistance of the sensors and compare the resistance to the tables on page 40 of this manual.</li> <li>• Replace the sensor if necessary.</li> </ul>



### 3 Troubleshooting *(continued)*

**Table 3G** (continued from previous page) *Troubleshooting Chart - Fault Messages Displayed on Appliance Interface*

FAULT	DESCRIPTION	CORRECTIVE ACTION
<p><b>Sensor Shorted</b> (will require a manual reset once the condition has been corrected. Press the RESET button on the display to reset.)</p>	<p>Either the inlet water or outlet water temperature sensor has been shorted.</p>	<ul style="list-style-type: none"> <li>• Check the sensors and their associated wiring. Repair or replace the sensor or wiring if damaged.</li> <li>• Measure the resistance of the sensors and compare the resistance to the tables on page 40 of this manual.</li> <li>• Replace the sensor if necessary.</li> </ul>
<p><b>Flue Sensor Open</b> (will require a manual reset once the condition has been corrected. Press the RESET button on the display to reset.)</p>	<p>The flue sensor has been disconnected or removed from the flue.</p>	<ul style="list-style-type: none"> <li>• Check the sensor and its associated wiring. Repair or replace the sensor or wiring if damaged.</li> <li>• Measure the resistance of the sensors and compare the resistance to the tables on page 40 of this manual.</li> <li>• Replace the sensor in flue.</li> <li>• Replace the sensor if necessary.</li> </ul>
<p><b>Flue Sensor Shorted</b> (will require a manual reset once the condition has been corrected. Press the RESET button on the display to reset.)</p>	<p>The flue sensor has been shorted.</p>	<ul style="list-style-type: none"> <li>• Check the sensor and its associated wiring. Repair or replace the sensor or wiring if damaged.</li> <li>• Measure the resistance of the sensors and compare the resistance to the tables on page 40 of this manual.</li> <li>• Replace the sensor if necessary.</li> </ul>
<p><b>Tank Open</b></p>	<p>Sensors equipped with an internal limit, the limit has opened due to temperature (195°F) or the sensor has become disconnected.</p>	<ul style="list-style-type: none"> <li>• Check the tank temperature.</li> <li>• Repair or replace the sensor wiring if damaged.</li> <li>• Replace the sensor if necessary.</li> </ul>
<p><b>Too Many Resets - Try Later</b></p>	<p>Too many manual resets have occurred during a 15 minute period.</p>	<ul style="list-style-type: none"> <li>• Wait 15 minutes and try again.</li> <li>• Turn power off to unit, wait 30 seconds, and then turn power back on.</li> </ul>
<p><b>Internal Fault</b></p>	<p>The main control board has detected an internal fault.</p>	<ul style="list-style-type: none"> <li>• Replace the main control board.</li> </ul>
<p><b>Writing to Memos</b></p>	<p>The main control board has detected an internal fault.</p>	<ul style="list-style-type: none"> <li>• Replace the main control board.</li> </ul>
<p><b>Delta T Shutdown</b></p>	<p>The temperature rise across the heat exchanger has exceeded the set parameters for the appliance.</p>	<ul style="list-style-type: none"> <li>• Verify that the system is full of water and that all air has been properly purged from the system.</li> <li>• Verify that the appliance is piped properly into the heating system. Refer to Section 6 - System Piping of the XP Plus Installation and Operation Manual for the proper piping methods for the XP Plus water heater.</li> <li>• Check for voltage to the appliance pump motor on a call for heat. If voltage is not present, check the wiring back to the pump relay. Replace the pump relay if necessary.</li> <li>• If 120 VAC is present on a call for heat and the water heater pump is not operating, replace the pump.</li> <li>• Verify that the appliance pump is the proper size. Reference Section 6 - System Piping of the XP Plus Installation and Operation Manual for appliance pump specifications.</li> </ul>

### 3 Troubleshooting

**Table 3G** (continued from previous page) *Troubleshooting Chart - Fault Messages Displayed on Appliance Interface*

<b>FAULT</b>	<b>DESCRIPTION</b>	<b>CORRECTIVE ACTION</b>
<b>Outlet Temp Shutdown</b>	Outlet water temperature has exceeded the maximum outlet water temperature.	<ul style="list-style-type: none"> <li>• Verify that the system is full of water and that all air has been properly purged from the system.</li> <li>• Verify that the appliance is piped properly into the heating system. Refer to Section 6 - System Piping of the XP Plus Installation and Operation Manual for the proper piping methods for the XP Plus water heater.</li> <li>• Check for voltage to the appliance pump motor on a call for heat. If voltage is not present, check wiring back to the pump relay. Replace the pump relay if necessary.</li> <li>• If 120 VAC is present on a call for heat and the appliance pump is not operating, replace the pump.</li> </ul>
<b>Watch Dog Error</b>	The main control board has detected an internal fault.	<ul style="list-style-type: none"> <li>• Replace the main control board.</li> </ul>
<b>Write EEPROM</b>	The main control board has detected an internal fault.	<ul style="list-style-type: none"> <li>• Replace the main control board.</li> </ul>
<b>CRC Parameters</b>	The main control board has detected an internal fault.	<ul style="list-style-type: none"> <li>• Replace the main control board.</li> </ul>
<b>No Error Stored</b>	The main control board has detected an internal fault.	<ul style="list-style-type: none"> <li>• Press the RESET button on the display panel.</li> </ul>

### 3 Troubleshooting *(continued)*

#### Combustion Analysis Procedure

1. Turn the main power off to the appliance by placing the “On/Off” switch in the OFF position.
2. Remove the flue sensor access cover to the upper left of the flue collar. Remove the flue temperature sensor from the flue collar leaving the sensor connected. **NOTE:** Combustion measurements will be taken from this location in the flue collar.
3. Insert the probe from a combustion analyzer into the hole left by the removal of the flue temperature sensor.
4. Turn the main power on to the appliance by placing the “On/Off” switch in the ON position.
5. Navigate to the Service Screen (FIG. 3-2) by pressing the SETUP button and scrolling to the SERVICE MAINTENANCE button. Select SERVICE MAINTENANCE.
6. On the Service Maintenance Screen place heater into Service Mode by selecting the START button, then selecting **Max Input** as shown in FIG. 3-2.
7. Once the appliance has modulated up to rate, measure the combustion. The values should be in the range listed in Table 3H. CO levels should be less than 200 ppm for a properly installed unit. If the combustion is not within range, reference the Troubleshooting Chart (Table 3I) on page 52 for possible causes and corrective actions.

Table 3H Flue Products

Flue Products	Natural Gas					
	1.25	1.5	2.0	3.0	4.0	ALL
Units	CO <sub>2</sub> (%)	CO <sub>2</sub> (%)	CO <sub>2</sub> (%)	CO <sub>2</sub> (%)	CO <sub>2</sub> (%)	O <sub>2</sub> (%)
Gas Valve						
Valve High	9.1	8.3	8.9	8.9	9.0	5.7 - 4.2
Valve Low	8.5	8.3	8.8	9.5	8.6	6.0 - 4.7
Propane						
Valve High	9.9	9.3	9.7	10.3	10.2	4.3 - 2.4
Valve Low	10.5	9.3	9.9	10.3	9.9	4.4 - 3.1
**All set points should be within +/- 0.5%** **CO levels should be less than 200 parts per million**						

8. Once the combustion analysis is complete, test the safety shutoff device by turning the manual gas shutoff valve to the OFF position and ensuring that the heater shuts down and registers an alarm. Open the manual gas shutoff valve and reset the control.
9. Turn the main power off to the appliance and replace the flue temperature sensor into the flue pipe connection.
10. Place the appliance back into normal operation.

**⚠ WARNING** You must replace the flue gas temperature sensor to prevent flue gas spillage into the room. Failure to comply could result in severe personal injury, death, or substantial property damage.

Figure 3-2 Service Screen

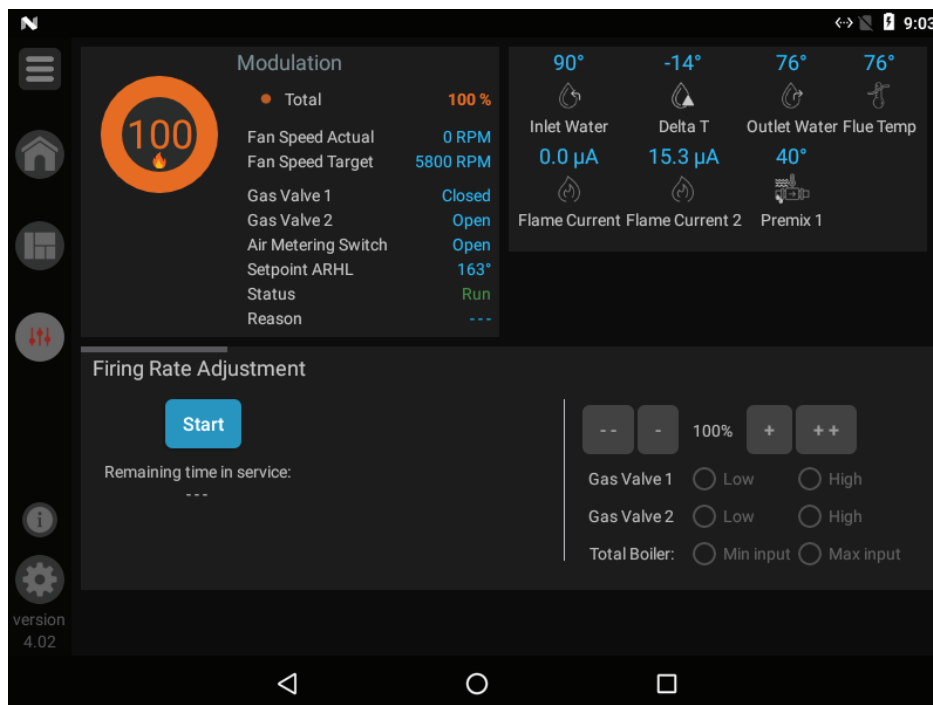

### 3 Troubleshooting

Table 3I Troubleshooting Chart - Combustion Levels

POSSIBLE CAUSE	CORRECTIVE ACTION
Vent/Air Intake Length or Obstruction	<ul style="list-style-type: none"> <li>Refer to Section 3 - General Venting of the XP Plus Installation and Operation Manual for the proper venting and air intake methods for the XP Plus appliance.</li> <li>Check for obstructions at the vent/air intake terminals.</li> </ul>
Gas Supply Pressure	<ul style="list-style-type: none"> <li>Refer to Section 7 - Gas Connections of the XP Plus Installation and Operation Manual for the proper gas supply for the XP Plus appliance.</li> </ul>
Dirty/Damaged Burner	<ul style="list-style-type: none"> <li>Refer to pages 35 - 36 of this manual for burner removal and cleaning procedures.</li> <li>Replace burner if necessary.</li> </ul>
Gas Valve Adjustment	<ul style="list-style-type: none"> <li>Refer to this page for the gas valve adjustment procedure.</li> </ul>

#### Gas valve adjustment procedure

**CAUTION** Under normal operating conditions this valve should not need adjusting.

Locate the throttle adjustment screw on the gas valve (see FIG. 3-3). Using a screwdriver, turn the screw a 1/4 turn **counterclockwise** to increase CO<sub>2</sub> levels or a 1/4 turn **clockwise** to decrease CO<sub>2</sub> levels. After one adjustment on the valve, follow the Combustion Analysis Procedure on page 51 of this manual to measure the combustion.

If combustion is still not within the specified range, repeat the procedure. This procedure **SHOULD NOT** be performed more than four (4) times. If combustion levels are not within specified range after four (4) adjustments, revisit the possible causes in Table 3I or contact A.O. Smith Corporation Technical Support prior to replacing the gas valve.

Figure 3-3 Gas Valve Adjustment

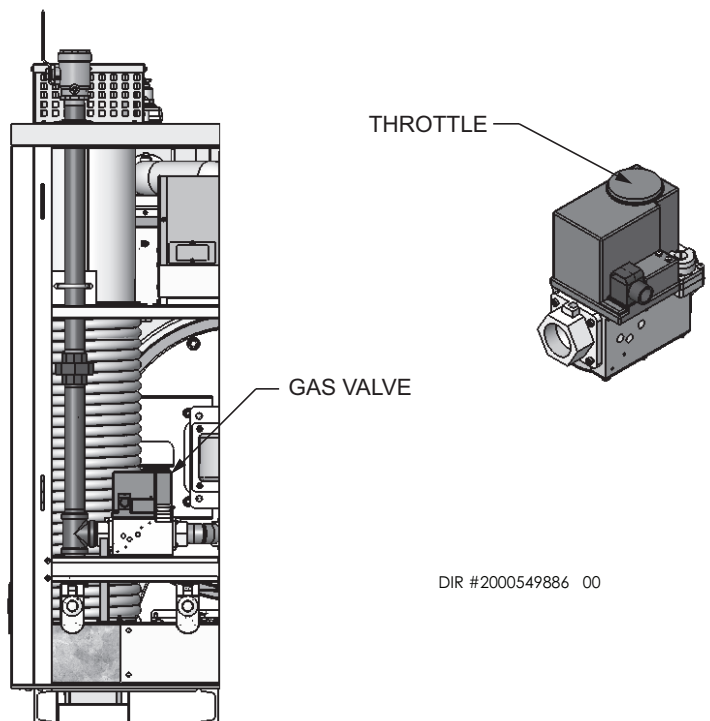

DIR #2000549886 00

---

# Notes

---

# Notes

---

# Notes

**Revision Notes:** *Revision A (PCP #3000024705 / CN #500014581) initial release.*

*Revision B (PCP #3000028201 / CN #500017801) reflects an update to the user interface screens.*

*MM #100307056\_DIR #2000559693\_Rev B  
10/18 - Printed in U.S.A.*